



General Operation and  
Service Manual for ReCoila®  
Series T, ST,C,LT



**Engineered Confidence**

Affix ID label here

[www.recoila.com.au](http://www.recoila.com.au)  
[www.recoila.co.nz](http://www.recoila.co.nz)

## **Overview**

The following operation, service and repair manual has been designed to give the operator/user a full understanding of the operational aspects of the hose and cable reels as well as being a supplement to our factory service and maintenance training course.

The basic principle of each reel is the same and the repair or service is carried out in the same manner from one model to the next, however certain models require higher levels of technical knowledge. These reels are listed separately and so are their respective parts breakdown.

## Models covered by this manual - T, ST, C and LT Series

This manual covers the following series of hose reels. Variations of each series or model may not be specifically listed such as stainless steel versions or a fully optioned reel, however, the procedures remain the same throughout the range for making repairs and service work as well as installation.

If you feel that the information does not reflect your specific hose reel please contact our customer service department for clarification.

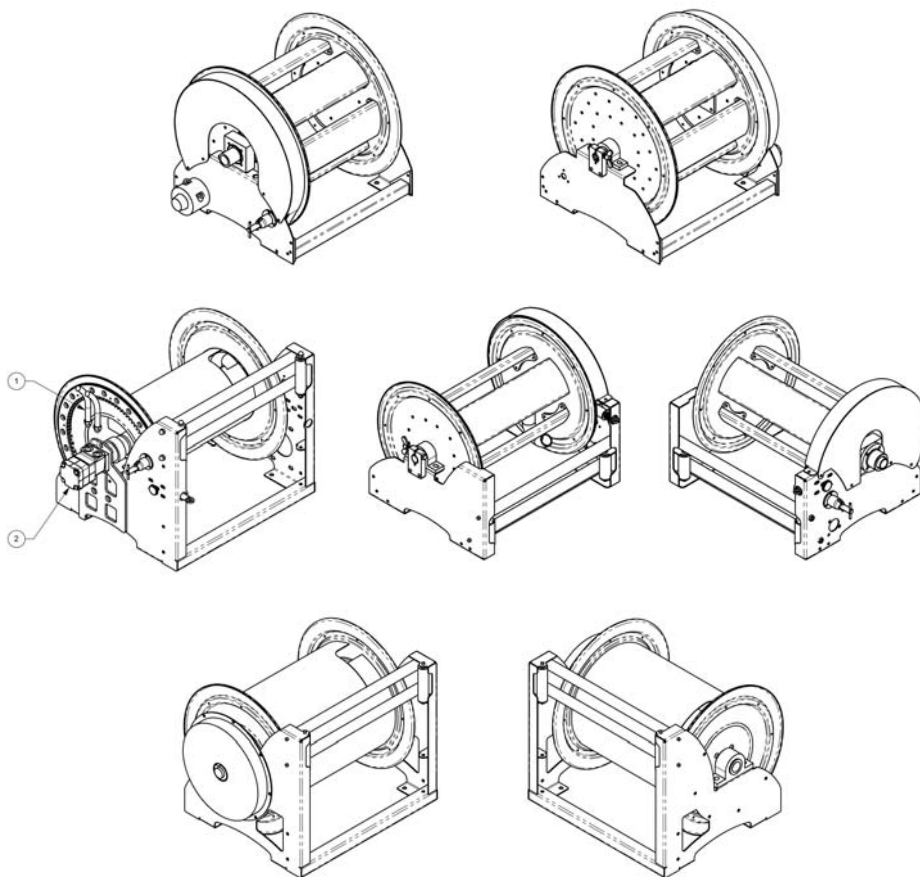

ReCoila® reserves the right to make changes to design and construction in line with ongoing product development without notification.

## Table of Contents

About us	5
<b>Quality and Certification</b>	
Declaration of Conformity	6
Listing of Precaution Symbols	7
ReCoila®'s Quality Statement	8
Terms and Conditions of Warranty	9
Procedure for Making Warranty Claims	10
Procedure for Returning Goods for Repair	11
<b>Installation instructions</b>	
Pre-Inspection	12
Mounting the Reel	12
Connection of the Inlet and Main Hose	13
Wiring Diagrams - Electrically Driven Reels	14
Plumbing Diagram - Air Drive Reels	15
Plumbing Diagram - Hydraulic Drive Reels	16
Installing the Main Hose	17
General Operation	17
<b>Maintenance</b>	
Lubrication	18
Fastener and Fixing Checks	18
Adding and Removing Tension	19
Checking for Leaks	19
Checking for Hose Defects	19
<b>Repair procedures</b>	
Replacing the Main "U" Cup Seal	20
Replacing Swivels	21
Replacing the Drive System	22
Adjusting and or Replacing the Friction Brake	23
Replacing or Servicing the Pin Lock	24
Replacing the Bevel Crank Drive	25
Replacing the Ratchet Locking Pawl	26
Removing the Spring Canister	27

## **About Us**

ReCoila® is a wholly Australian owned company with a manufacturing facility in the industrial precinct of Kings Park situated in the western region of Sydney.

ReCoila® has been manufacturing quality hose reels for some 30 years, servicing both domestic and international markets.

Our range of reels includes composite spring rewind hose and cable reels, fabricated steel reels in powder coated finish, stainless steel and aluminium with hand crank, and motorised versions.

ReCoila® as a manufacturer, offers an extensive range of Australian made hose, cord and cable reels, this range is supplemented with selected products from renowned quality manufacturers in the USA and Europe to bring you the most comprehensive range of hose, cord and cables reels.

Our stringent in-house testing ensures all products meet the quality that you expect from ReCoila®, whether it be an Australian made reel or manufactured elsewhere and distributed by us. Our aim has always been to design and manufacture the best reels available at a cost effective price.

We continue to lead the way in design, innovative ideas, functionality and reliability of our products and utilise state of the art manufacturing methods, setting the standards for others to follow.

ReCoila® is committed to continued quality and engineering excellence balanced with price competitiveness to supply users with the best reels available.

Hence we proudly say

**“Engineered Confidence”**

## CE Declaration of Conformity

We,

Strata Group (Aust) Pty Ltd  
Unit 1/10 Melissa Place  
Kings Park NSW 2148  
Australia  
Phone: (61) 2 9621 8988  
Fax: (61) 2 9621 7688

Declare under our sole responsibility that the product ReCoila<sup>®</sup> Spring rewind hose cord and cable reels, to which this declaration relates, is in conformity with the following documents.

Strata design specifications and acceptance criteria following the provision of 98/37EC (Machinery Directive).

The technical construction file is maintained at the following addresses:

1.

Strata Group (Aust) Pty Ltd  
Unit 1/10 Melissa Place  
Kings Park  
NSW 2148  
Australia  
Phone: (61) 2 9621 8988  
Fax: (61) 2 9621 7688

2.

Reelcare  
Unit L Tyson Courtyard  
Weldon South Industrial Estate  
Corby Northamptonshire NN18 8AZ  
United Kingdom  
Phone: (44) 1536 407001  
Fax: (44) 1536 261491

## Listing of Precautions Symbols



Means Warning! Watch out! There are possible hazards with this procedure! Possible hazards are shown by this warning symbol.



Means Warning! Moving parts. Keep away from moving parts and pinch points.



Means Warning! Item under tension. This area contains a tensioned spring or a pre loaded component.



Means Warning! Never let the hose or cable rewind uncontrolled. You must be mindful of your surroundings and those within it. Uncontrolled rewinds are extremely dangerous.



Means qualified trades person or those that are authorised and trained with a full working knowledge of the service or repair task being carried out, possible hazards. Means electrical connections are present be careful, ensure the item is isolated before service.

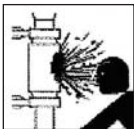

Means, this area and or item is pressurized. Show extreme caution, even low pressure systems can be extremely dangerous.

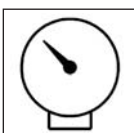

Means do not exceed designed maximum working pressure.



Means check to ensure you are wearing and have on hand, all appropriate personal safety items as well as those that may be in or entering the work zone.

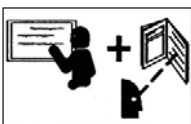

Means, consult the service centre or become trained and read the service manual. Additional training may be required to ensure you are familiar with your local authorities' rules and regulations on compressed gases and liquids, correct and safe hose management.

## **Strata Group (Aust) Pty Ltd's Quality Statement**

All ReCoila<sup>®</sup> Self-Retracting hose and cable reels are built with quality in mind. Our in-house quality system requires us to check raw materials and sub-contracted components to ensure they meet the standard of engineering we require in order to offer the best possible product on the market.

During the four stages of manufacturing each sub-assembly is checked to ensure functionality and dimensional correctness. Specific components such as swivels and slip-rings are checked at the sub-assembly stage and during final assembly to ensure they pass low pressure and high pressure tests. Slip-rings are checked for electrical continuity and earth leakage.

A final assembly check is carried out before packing to ensure the reel retracts correctly and the locking system is functioning correctly.

Our in-house quality system is backed by our warranty should undetected or unforeseen failures occur.

## **Terms and Conditions of Warranty**

### **The one year Limited Warranty Statement**

Strata Group (Aust) Pty Ltd affirms its product confidence with the following warranty.

All products manufactured by Strata Group (Aust) Pty Ltd are warranted to be free of defects in material and workmanship for Twelve (12) months from the date of invoice.

Strata Group (Aust) Pty Ltd's liability shall be limited to repair or replacement of defective material within the warranty period when returned freight paid to its plant or service depot designated by Strata Group (Aust) Pty Ltd.

The warranty does not cover damage caused by accident, misuse, use in applications other than for which the reel was designed, abuse or faulty installation or normal wear and tear. Strata Group (Aust) Pty Ltd products must be installed and maintained in compliance with the manual of instructions furnished with each reel.

### **Extended five year Limited Warranty**

The listed items have an extended five (5) year limited warranty

- Swivel component - sleeve and shaft.

### **Extended two year Limited Warranty**

The listed items have an extended Two (2) year limited warranty

- Spring and Plastic components.

### **The one and two year Warranty does not include the following:**

**Hose** - these are warranted by the respective hose manufacturers.

**O-rings** - are limited to three (3) months.

## **Procedure for Making Warranty Claims**

### **Reels sold in Australia**

Should you consider that the failure of the item is subject to warranty please follow the listed procedures.

### **R.G.A. (Returned Goods Authority)**

You are required to obtain an R.G.A. This can be obtained by phoning the Strata Group (Aust) Pty Ltd sales desk. Providing sufficient information is given an R.G.A. will be issued. The number must be clearly marked on the item. Goods returned without an R.G.A. will not be accepted from the carrier and will be returned by the same.

### **Proof of date of sale/purchase**

Proof of sale or of purchase is required and you need to send proof of date of sale or purchase with the item in question. Copies of invoices or sales dockets are considered sufficient proof.

### **Full and complete contact details**

Your complete contact details must be included with the item in question.

### **Freight and method of return**

The items are to be returned to the place of purchase, freight paid. Strata Group (Aust) Pty Ltd will pay for freight from the place of purchase to its nominated plant or service centre. No goods will be accepted at these nominated places, receiver to pay.

Providing that the item being returned is considered to be under warranty and our technicians confirm this on inspection, Strata Group (Aust) Pty Ltd will make the necessary repairs and return the item free of charge.

If the item is found to be faulty due to a non warrantable fault the item will be quoted for repair and freight will be charged both ways unless the customer has nominated their own freighter, then freight will be charged for the initial return to us.

Goods not found to be faulty under warranty, please refer to service and repair terms and conditions.

**Countries outside of Australia refer to your nearest distributor or the place of purchase.**

## **Procedure for Returning Items for Service or Repair**

### **For reels sold within Australia**

The following procedure covers items being returned for service or repair not covered by warranty.

### **R.G.A. (Returned Goods Authority)**

You are required to obtain an R.G.A. This can be obtained by phoning Strata Group (Aust) Pty Ltd sales desk. Providing sufficient information is provided by you, an R.G.A. will be issued. The number must be clearly marked on the item. Goods returned without an R.G.A. will not be accepted from the carrier and will be returned by the same.

### **Customer order number**

You are required to supply an official purchase order number for the repair which is to be returned with the item or faxed through to the service centre. For non account customers (such as an end-user) returning goods, you will be required to confirm some type of payment method such as credit card. Items returned without an accompanying purchase order or confirmed method of payment will not be quoted until such time that these details have been received.

### **Full and complete contact details**

Your complete contact details must be included with the item in question.

### **Freight and method of returned**

The items are to be shipped to a Strata Group (Aust) Pty Ltd nominated plant or service centre. No goods will be accepted at these nominated places with receiver to pay unless prior arrangement has been made to ship the item on Strata Group (Aust) Pty Ltd freight account whereby you will be invoiced freight cost at the going rate.

### **Quotation for the repair**

The items returned will be quoted for the cost of the repair and a copy will be faxed through to the customer for approval. The customer has seven days to confirm the repair.

If confirmation is not received within seven days the item will be returned by the nominated freight company or on Strata Group (Aust) Pty Ltd freight and a minimum service quotation fee will be charged. This quotation fee is \$30.00 plus any freight costs.

### **Sale or disposal of unclaimed/non confirmed items**

For items sent for warranty or repair that have not been collected or confirmed to be repaired or sent in without full customer details after a period of three months of receipt Strata Group (Aust) Pty Ltd reserves the right to dispose of, or sell any such items to recoup any costs, no claim against Strata Group (Aust) Pty Ltd will be recognised.

**For reels purchased outside of Australia refer to your nearest distributor or the place of purchase.**

## Pre-inspection

- Check the reel for shipping damages.
- Ensure all parts are supplied as ordered.
- Record the Model Number and Serial Number for future reference.
- Complete the warranty registration form contained within this manual and return to ReCoila® affirming your year warranty period.
- We recommend that you check and re-lubricate bearing and moving parts as described in the maintenance section to ensure smooth reliable operation.

## Installation section

### Mounting

- Ensure the mounting surface is flat and rigid to prevent twisting the frame and causing the reel to bind during operation.
- The reel is fastened down through the four bolt holes in the bottom plate, measure the pitch and drill your mounting frame accordingly.
- The minimum fastener requirement is M10 nuts, bolts and washers, however you should evaluate the working load and operation of your installation to ensure the correct size and strength fastener is being used.
- Tighten the reel down and check that the spool rotates evenly without binding.

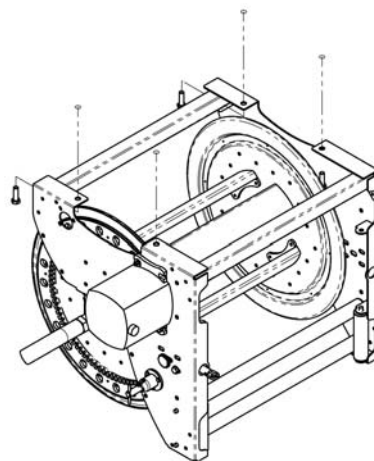
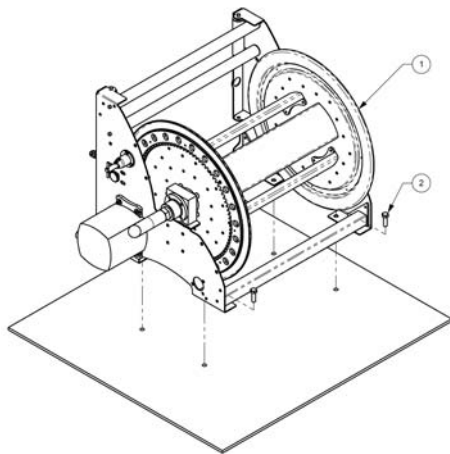

### Connection of the Inlet and Main Hose/s (spring reels further on) - Fig 1 & Fig 2

- A **flexible** connection between the reel and the source of supply (Fig 1 item 1 & 2) is required to prevent possible misalignment and binding. Non flexible connections will void the warranty. The pressure rating of the inlet hose must be equal to or greater than the rating of the reel.
- Always check with your local authorities for appropriate rules and regulations for safe use and handling of compressed gases, liquids and fuel gases.
- Using the appropriate approved hose and fittings, connect the supply line to the inlet connection of the reel.
- Ensure you use thread sealants where applicable and permitted.
- Never over-tighten or under-tighten fittings.
- Once connection has been made to the inlet of the reel ensure you make or fit a connection to the outlet of the reel (Fig 2 items 1 & 2) then turn the supply valve on slowly and check for leaks.
- It is recommended that the hose be **wound on fully charged**, this will help in preventing flattening of the hose during rewind, ensuring maximum flow rates and least spool damage.

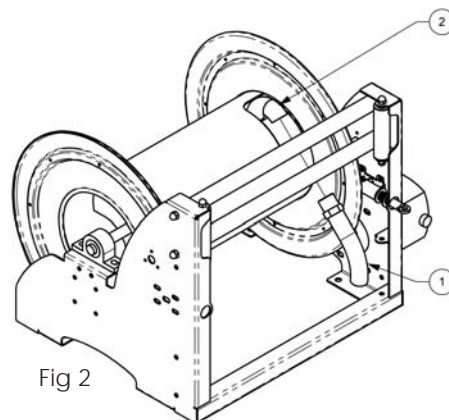
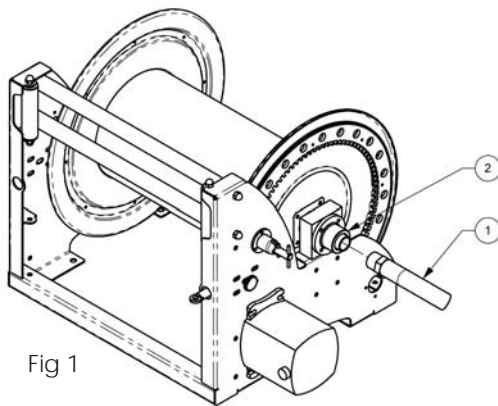

**Wiring Diagram 12 & 24 VDC Electrically Driven Reels - Fig 3**

- Ensure all wiring and connections between the motor and supply are compatible. Check with your local authorities to ensure you comply with local wiring specifications and procedures.
- Use the correct size circuit breaker or fuse to protect the motor and wiring systems.
- The diagram below allows for single direction powered rewind. It may be desirable to power drive the hose in and out, in that case your electrician can wire a reversing switch into the circuit.

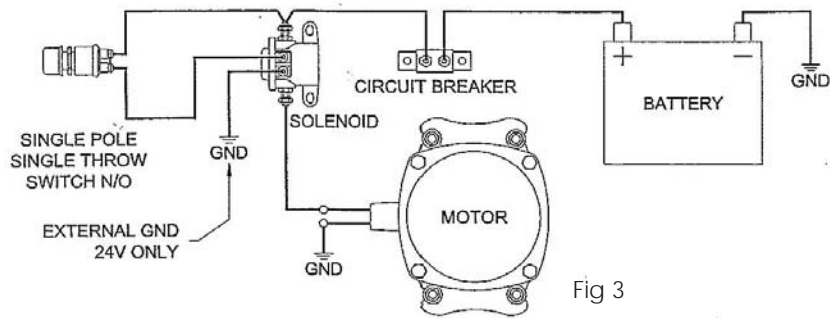

Fig 3

**Wiring Diagram 110/240 VAC Electrically Driven Reels - Fig 4**

- Ensure all wiring and connections between the motor and supply are compatible. Check with your local authorities to ensure you comply with local wiring specifications and procedures.
- Use the correct size circuit breaker or fuse to protect the motor and wiring systems.
- The diagram below allows for single direction powered rewind. It may be desirable to power drive the hose in and out, in that case your electrician can wire a reversing switch into the circuit.
- Primary supply can be provided via a transformer see your local authorities for specifications.

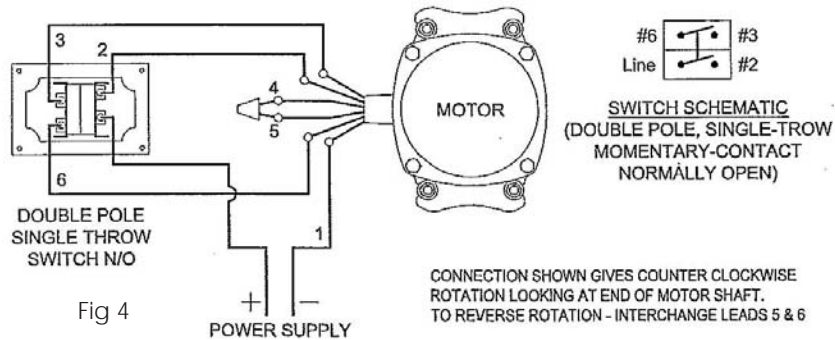

Fig 4

**Plumbing Diagram Air Drive Reels - Fig 5, Fig 6 & Fig 7**

- Ensure all supply lines are capable of supplying sufficient volume of air and pressure for correct operation and power of the drive system.
- Air drive systems require lubrication and we recommend the installation of an in-line lubricator.
- Fig 5 shows the connection ports for the air supply. One or both ports may be required pending how you require the system to operate.
- Fig 6 shows single direction rotation.
- Fig 7 shows plumbing for power wind in both directions.

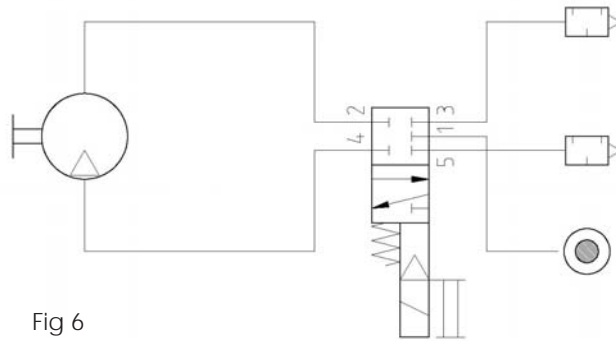
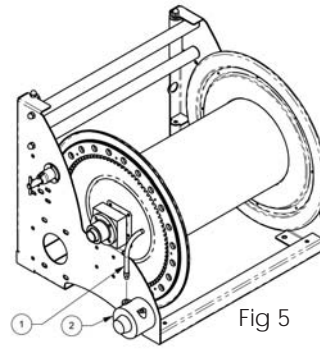

Fig 6

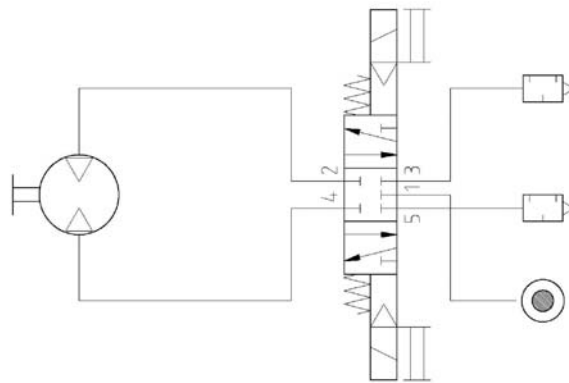
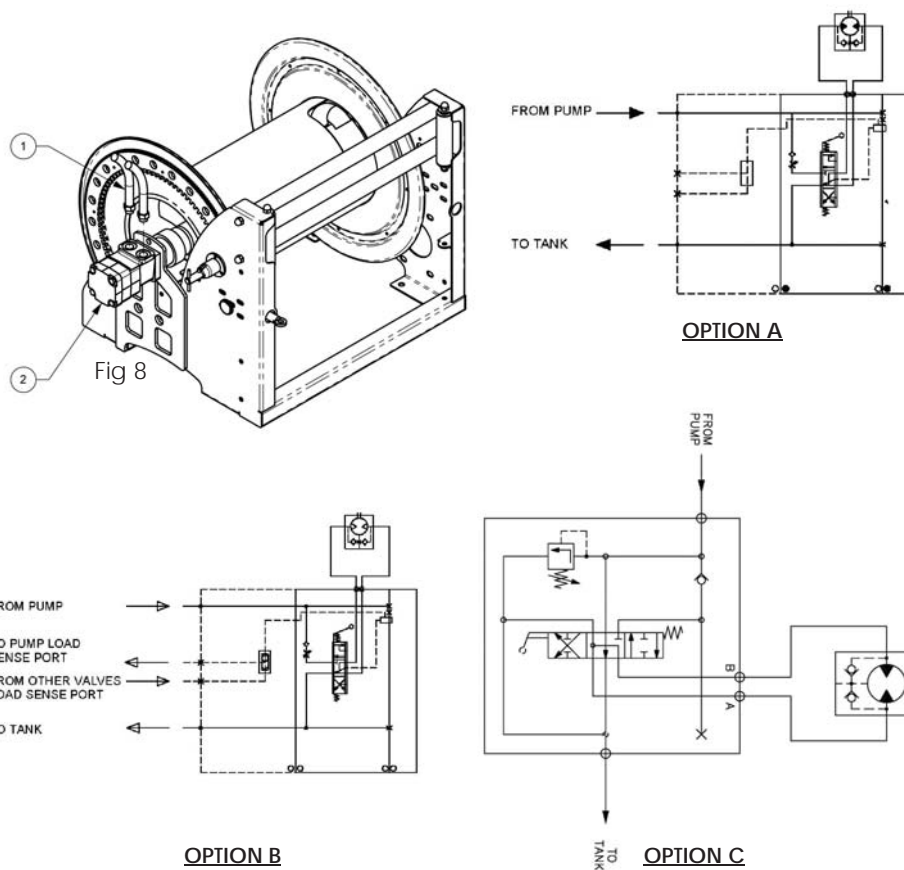

Fig 7

## Plumbing Diagram Hydraulic Drive Reels - Fig 8, Fig 9, Fig 10 & Fig 11

- Ensure all supply lines are capable of supplying sufficient volume of oil and pressure for correct operation and power of the drive system.
- The schematics below have allowed for forward and reverse control with proportionate control and a free wheel operation.
- Fig 8 shows the connection ports for the oil supply.
- Option A - Typical connection to an existing variable displacement pump, pressure compensated pump system. Connection to a fixed displacement pump, when the pump unloading is done via other valves in the system.
- Option B - Connection to an existing variable displacement load, sensing pump system.
- Option C - Connection to a fixed displacement pump (when the motor is the only function in the system).



## **Installing the main hose**

This procedure is designed to help you fit the main hose.

- Lay the hose out along the floor.
- Apply an appropriate thread sealant (check with your local authorities) to the hose fitting and fit the hose into the gooseneck. Fit your stop valve or nozzle to the other end of the hose.
- Ensure you have removed all kinks from the length of hose.
- Bring the reel up to pressure and vent the line if need be.
- Grab the flanges of the reel and wind the hose on. On spring rewind models, you will hear a lot of banging and rumbling as the spring arbor winds backwards in the spring.

### **Spring rewind models**

- Once the hose is fully wound on the reel, hold the hose on the spool and rotate as if you were pulling the hose off, holding the hose against the spool so it does not come undone. Rotate the spool three full turns, this sets the spring's pretension.
- Feed the hose through the roller guide and fit the hose bumper.
- Pull all of the hose from the reel and rewind, if there is not enough tension remove the hose bumper and roll on another turn. Note: too many preset turns will prevent all of the hose being pulled off the reel.

## **General operation**

Once your reel is bolted down, the supply and main hose is connected and purged and the rewind system activated, we recommend you take a few minutes to trial run the reel. Pull or power several meters of hose off the reel and rewind it. This will help you understand the functionality of the reel. Your company may wish to develop a procedure for operation and use, so others can be safely trained on the operation of this equipment.

Note: due to the changing liner retraction rates of a filling and emptying spool, the system may seem to rewind at different speeds over the length of the hose. When the spool is empty (all the hose is out), the rewind speed will seem slow and speed up as you wind more hose on. We try to engineer average rewind speed to be approximately 800mm per second, however this will be dependent of the size of the reel you may have chosen for you application.

## **Maintenance section**

The pictures shown are for pictorial explanation and may not necessarily be identical to the model or unit you are installing or servicing.

The following section is designed to offer some technical advice on general maintenance and repair of your hose reel. The level of maintenance and the frequency will be dependant on the use, application and environment your hose reel is subjected to.

We recommend a service schedule procedure be prepared by your company so potential faults or failures can be realised before they become catastrophic, rendering the equipment out of action or cause injury.

For service requirements outside those listed, please contact ReCoila® or your nearest distributor.

### **Lubrication**

As part of any standard maintenance procedure we recommend you periodically apply suitable lubricants to the main bearings, gear drive systems, or where there is metal to metal contact. Gear box oil levels also need periodic checks. Seals and O-rings will also need periodic checks and lubricant applied.

### **Fastener and fixing checks**

We recommend you periodically check to ensure the fasteners and fixings are tight and not working loose.

### **Adding and removing tension**

This procedure guides you through adding and removing tension on spring rewind reels.

To add tension:

- Remove the hose bumper - ensure you securely hold the hose.
- Feed the hose back through the roller guides.
- Wind the hose forward as if you were pulling some off the reel, instead, hold the hose tight to the spool and rotate one full turn.
- Add only one full turn at a time.
- Slide the hose through the roller guide and re-fix the hose bumper.
- Test the tension by pulling all the hose off the reel and rewinding it.
- Repeat the process until the desired pretension is achieved.

To remove tension:

- Hold the hose securely, remove the hose bumper and feed back through the rollers.
- Allow the spring to wind – rotating the spool until it stops, note to keep firm control of this process.

### **Checking for leaks**

Like all moving and rotating components there is a need to make regular maintenance checks. Some of these checks are very simple and only require a visual inspection, others require service work to be carried out on items, such as seals and O rings.

From time to time we recommend that the user check for leaks, liquid leaks are easily found, however gas leaks require some form of leak test, it may require the services of a professional test and certifying authority or a simple soapy water test. Soapy water brushed around each joint will soon indicate a leak when bubbles appear.

We recommend you prepare a maintenance schedule and procedure that checks for leaks.

### **Checking for hose defects**

Regular checks should be made to ensure safe operation of the hose and fittings. These checks should be carried out by authorised personal trained in this service and should form part of your maintenance procedure schedule.

## Repair Procedures

### Replacing or lubricating the main "U" cup seal - Fig 100

- Isolate supply and drive services before carrying out any service or maintenance work.
- Item 1 - your supply hose.
- Item 2 - swivel head coupling.
- Item 3 - swivel shaft.
- Item 4 - U cup seal.
- You will need to depressurize the hose reel and safely drain the hose, check with your management regarding any hazardous issues with the products within the liquid, gas or vapor.
- Remove the four bolts holding the swivel head coupling on to expose the U cup seal.
- Remove the U cup seal from the recess in the swivel head coupling, clean all surfaces and check for damage. Any dents or scratches will cause the seal to leak again.
- Apply an appropriate type of lubricant to all surfaces, re-fit the seal and re-assemble the coupling.
- Check for leaks.

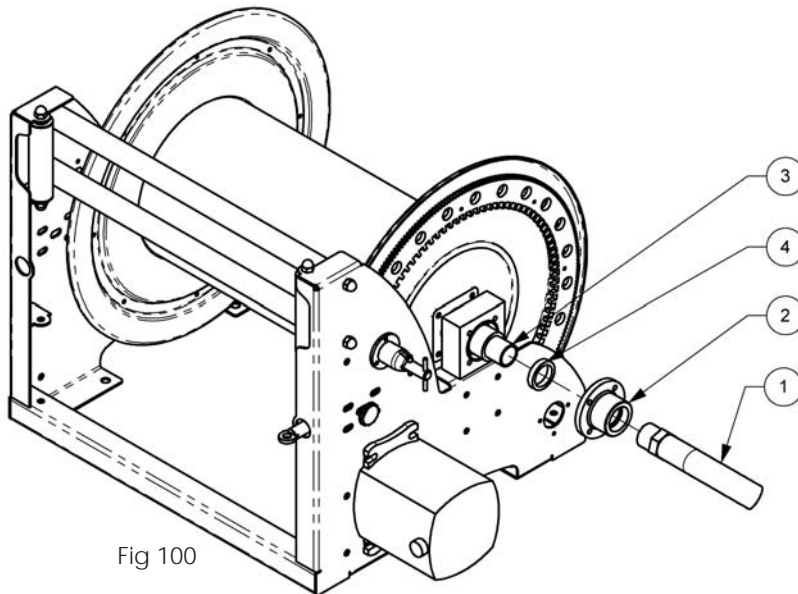

Fig 100

### Replacing swivels - Fig 101

- Item 1 - your supply hose.
- Item 2 - swivel coupling.
- Item 3 - swivel shaft.
- You will need to depressurize the hose reel and safely drain the hose, check with your management regarding any hazardous issues with the products within the liquid, gas or vapor.
- Remove the swivel coupling.
- For servicing swivel couplings, instructions are provided with the seal kit.
- Check for leaks.

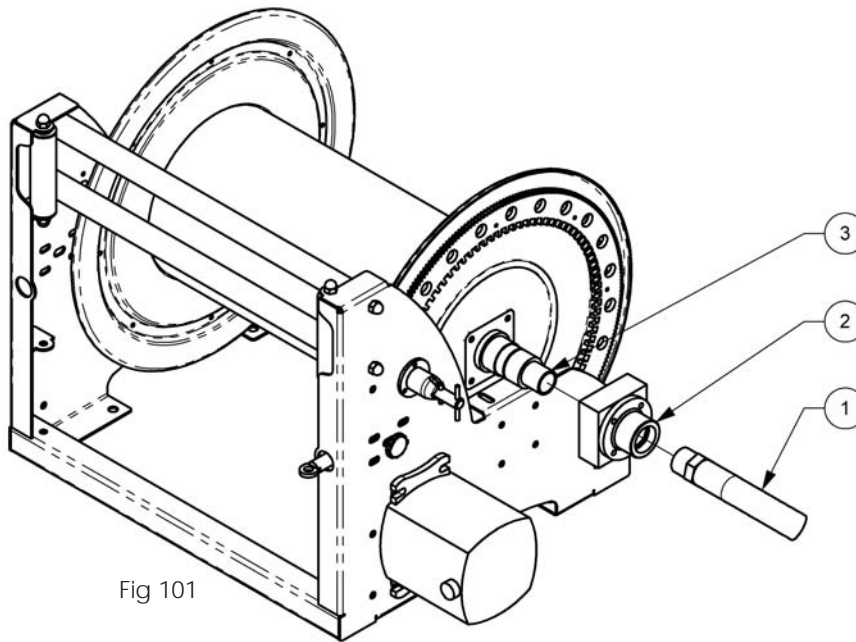
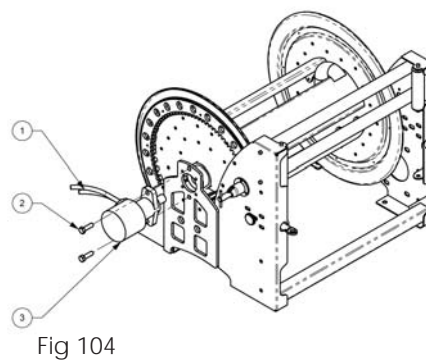
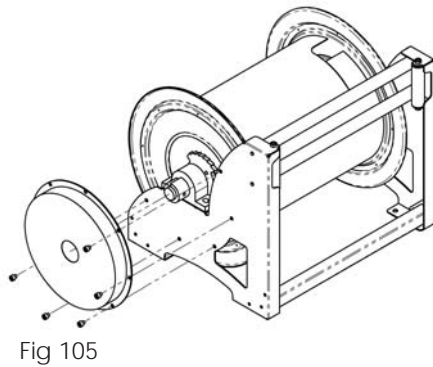
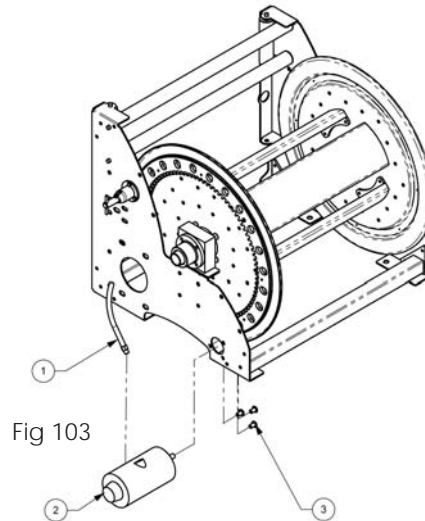
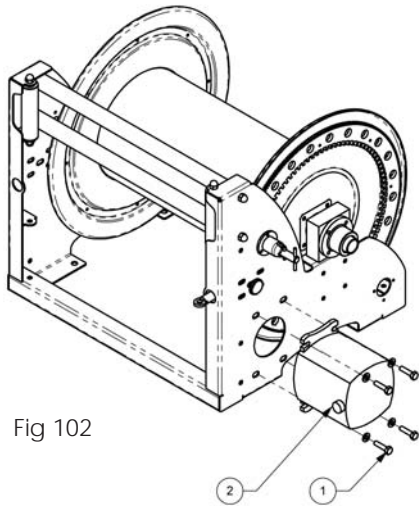

Fig 101

### Replacing the drive system - Fig 102, Fig 103, Fig 104, Fig 105

- Ensure electrical reels are isolated, hydraulic and pneumatic supply systems are disconnected and depressurized before carrying out any drive system change.
- Disconnect the supply lines.
- Loosen fasteners and remove the drive system.
- Fig 102 - 12 & 24 VDC, 110 VAC, 240 – 415 VAC, Gear drive hydraulic drive systems
- Fig 103 - air drive systems
- Fig 104 - direct drive hydraulic
- Fig 105 - spring drive systems, see further on in this manual for details.



### Adjusting and or replacing the friction brake - Fig 106

The friction brake has been designed to allow the operator to preset an amount of friction to reduce spool over-run.

- Isolate supply and drive systems before carrying out any service or maintenance
- To add or remove friction, adjust the wing nut on the friction brake.
- To remove the friction brake altogether, undo the two fasteners as shown below.

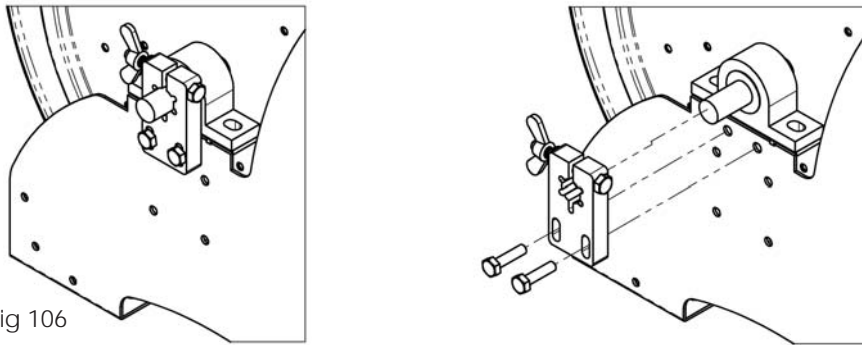

Fig 106

### Replacing roller guides and roller guide bearings - Fig 107

It may be necessary to replace the ball bearing bearings in the roller guides as described below.

- Isolate supply and drive system before carrying out any service or maintenance work.
- Undo the dome nuts at either end of the roller.
- Slide the roller rod out of the roller.
- Remove the bearings and replace.
- Refit the roller and slide the roller rod back into the roller.
- Refit the dome nuts using a thread locker. Be careful not to leave the nuts too loose or too tight which will pinch the roller preventing it from rotating.

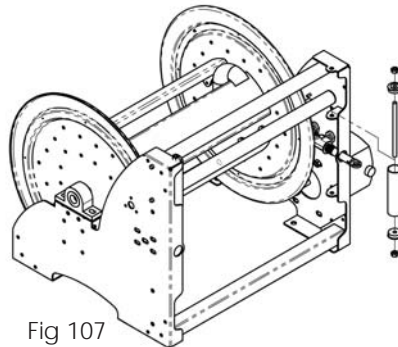

Fig 107

### Replacing or servicing the pin lock - Fig 108

Replacing or servicing the pin lock, in both cases the pin lock has to be removed, follow the instructions below.

- Isolate supply and drive systems before carrying out any service or maintenance work.
- Undo the three bolts holding the pin lock in place.
- To replace the spring within the pin lock tap out the spring pin.
- Remove the spring and replace, some lubricant should be applied to the inside of the housing.
- Reset the spring pin and check operation.
- Refit and align the pin with the pin lock ring gear.

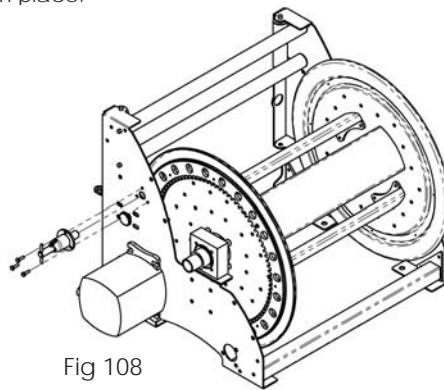

Fig 108

### Replacing the ring gear/pin lock ring - Fig 109

Replacing the ring gear or pin lock ring equates to the same procedure. Care must be taken to check the alignment of the pin lock and the bevel gear if this option is fitted.

- Isolate supply and drive systems before carrying out any service or maintenance work.
- Remove the main hose from the reel.
- Remove drive system - see previous procedure.
- If pin lock fitted, pull pin to disengage and lock in the disengaged position.
- Undo and remove the spool bearing bolts.
- Remove the spool from the frame.
- Undo and remove the ring gear or pin lock ring.
- Refit the spool and fasteners.
- Check the alignment of the pin lock and bevel gear if fitted. If the spool does not rotate correctly realign the spool on the frame and re-tighten the bearing blocks.

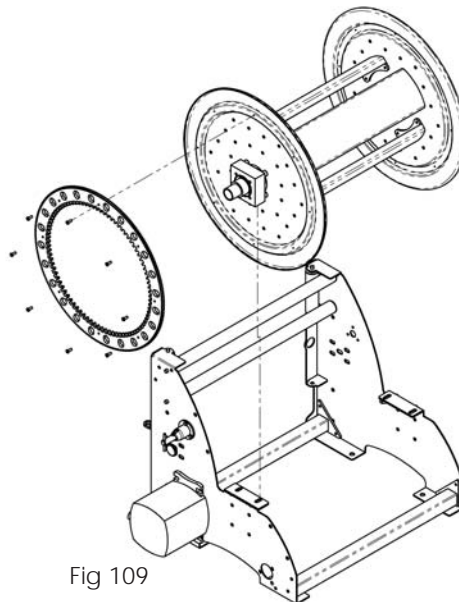
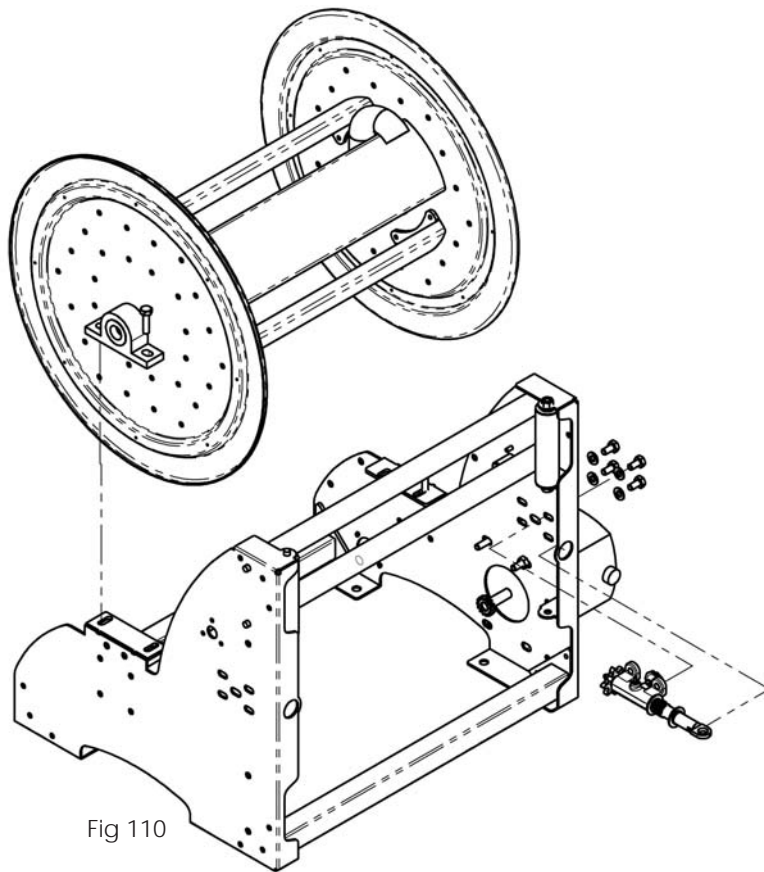

Fig 109

### Replacing the bevel crank drive - Fig 110

Where the bevel crank option is fitted, use the following procedure to fit or replace the bevel crank drive. The alignment between the bevel gear and the ring gear drive is important for correct rotation and may require trial and error fitment to obtain the best alignment.

- Isolate supply and drive systems before carrying out any maintenance or service work.
- Undo the locking knob in the side of the reel.
- Undo the four bolts that secure the bevel crank drive.
- Remove the bevel crank drive.
- Disassemble the bevel drive as per schematic below.



### Replacing the ratchet locking pawl (spring reels only) - Fig 111

The following procedure demonstrates how to replace the ratchet locking pawl on the spring driven hose reels.

- Isolate supply before carrying out any service or maintenance work.
- We also recommend that you de-tension the reel before making any repairs - see 'adding and removing tension' on page 19.
- With a pair of long nose pliers remove the pawl spring.
- Undo the locking nut on the pawl and remove the pawl.
- Replace the pawl.

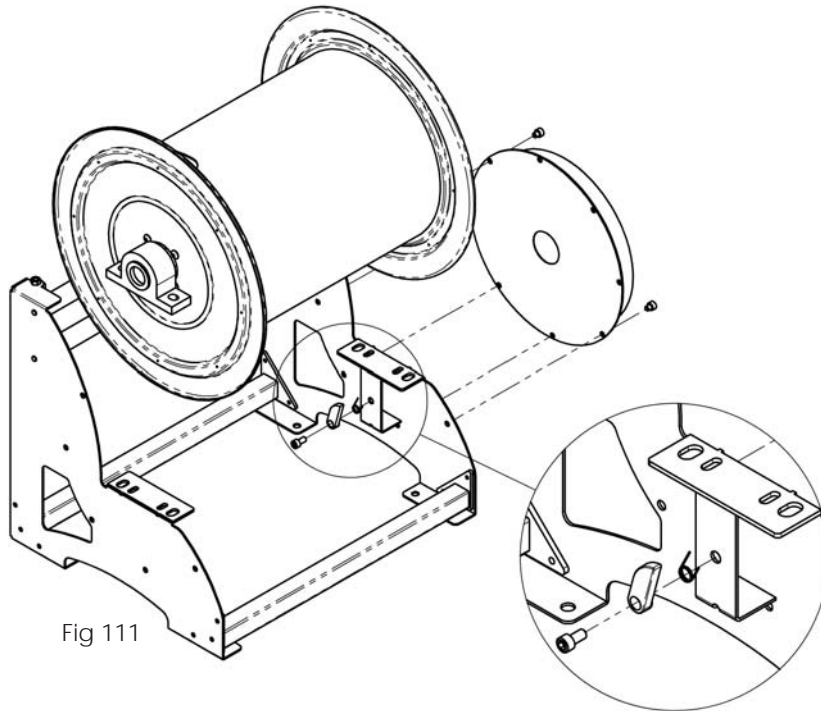
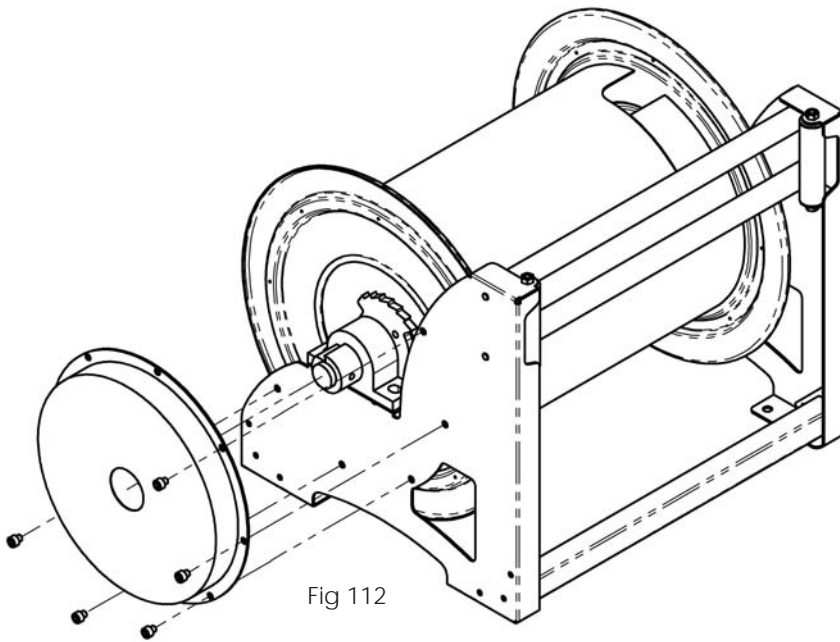

Fig 111

### Removing the spring canister (spring reels only) - Fig 112

This procedure guides you through removing and replacing the spring canister.

- Isolate supply before carrying out any service or maintenance work.
- Ensure the reel is de-tensioned - see 'adding and removing tension' on page 19.
- Undo **only** the fasteners around the spring canister that secure it to the frame. **Do not** undo all the fasteners that hold the backing plate on the spring canister.
- Slide the spring canister off the drive axel.
- Replace the entire spring canister, **do not open** the canister unless you have original factory equipment designed to do so.



T Series Electric Motor Exploded View - Fig M1

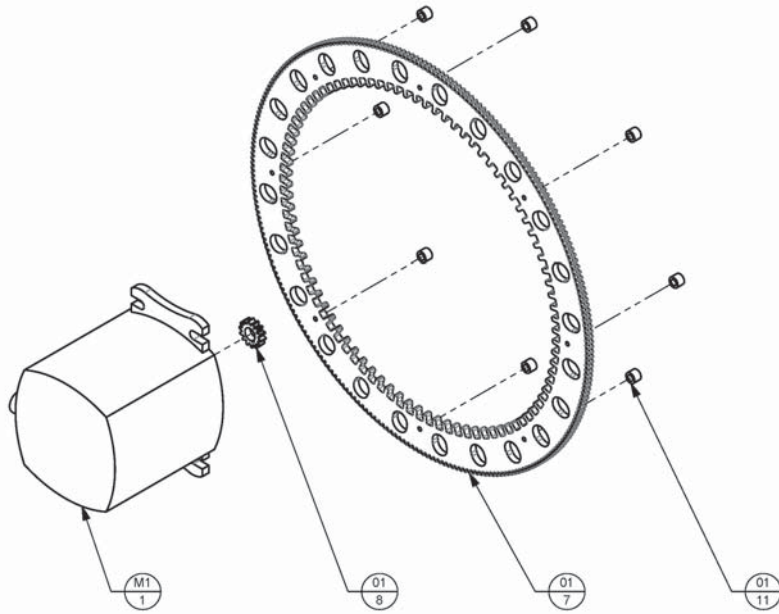

FIGURE M1

T Series Hydraulic Motor Exploded View - Fig M2

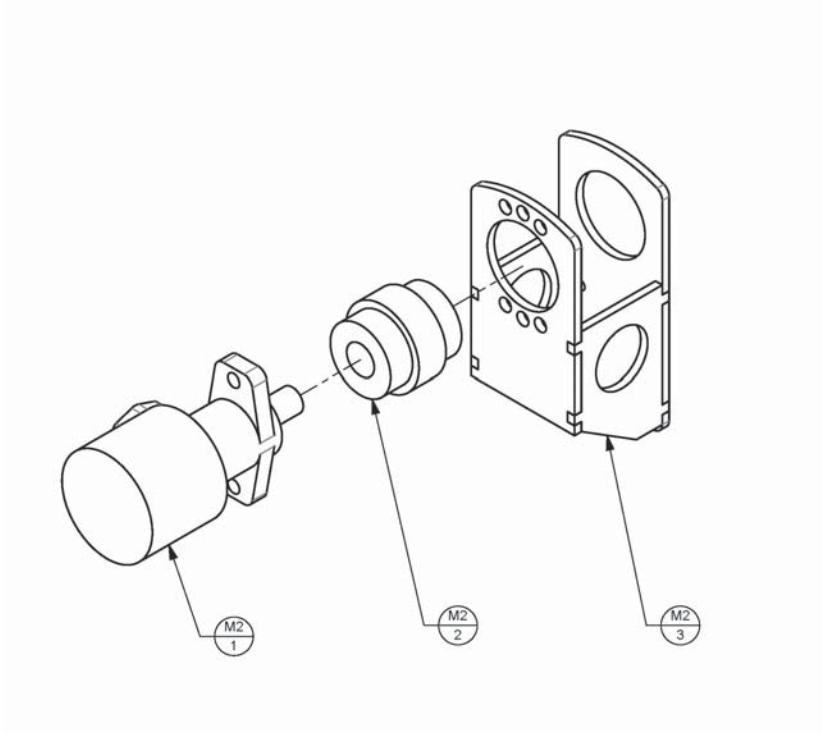

FIGURE M2

T Series Hydraulic Motor Exploded View - Fig M3

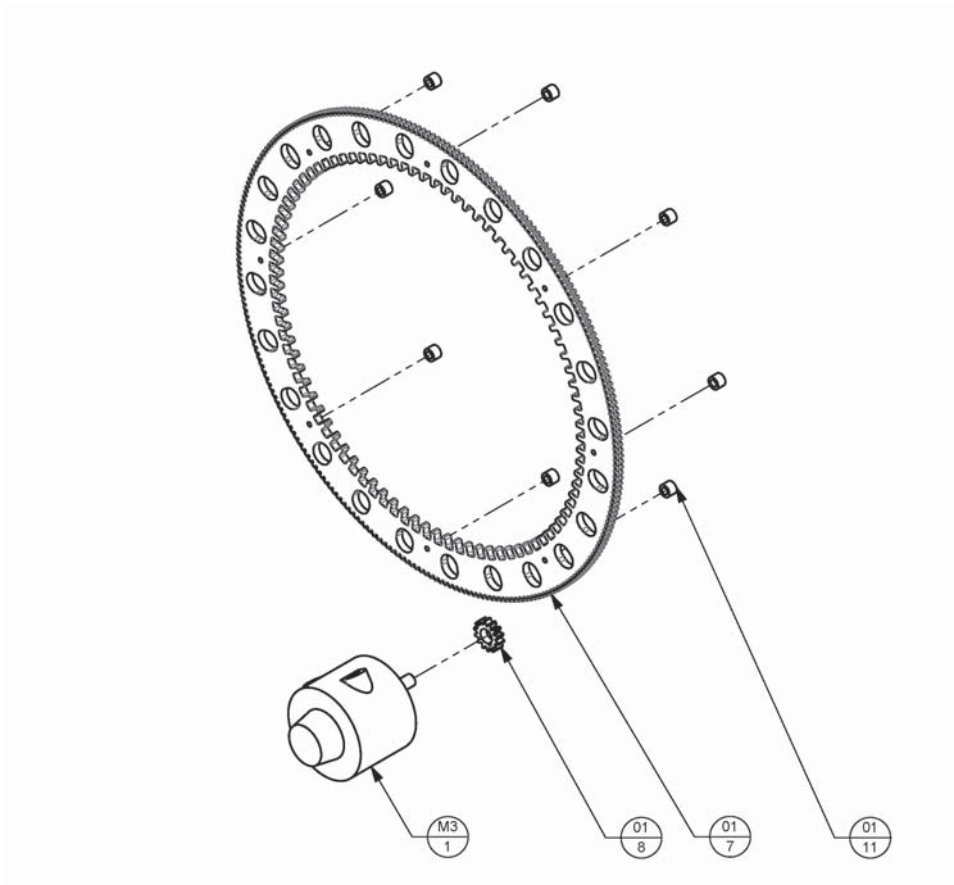

FIGURE M3

C Series Motor Exploded View - Fig 02

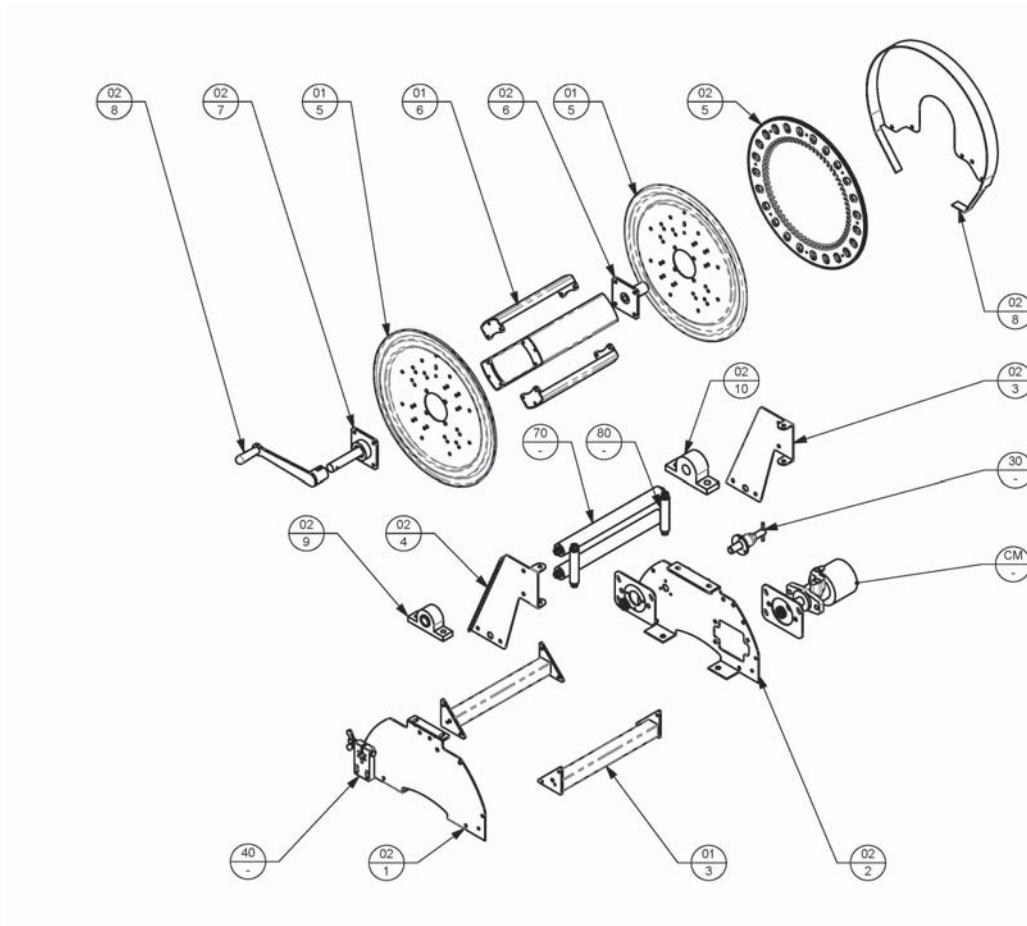

FIGURE 02

C Series Motor Exploded View - Fig CM

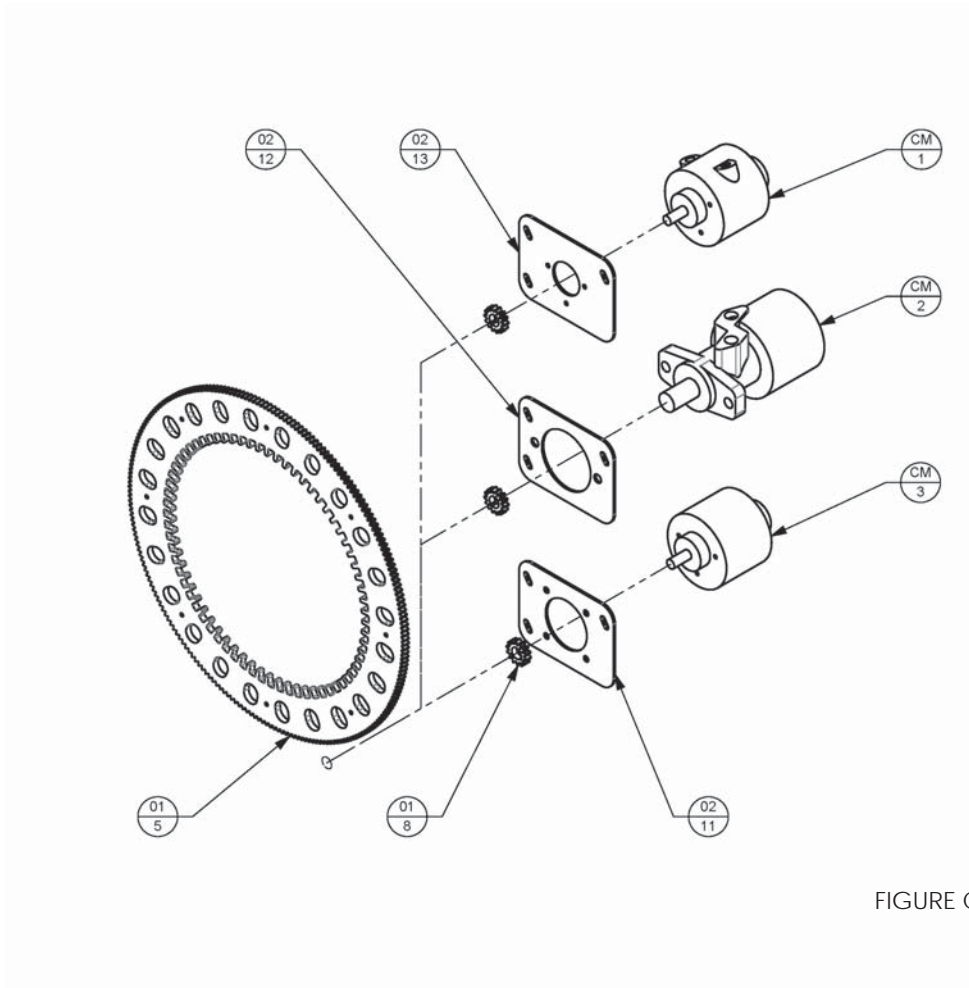

FIGURE CM

T Series Assembly Exploded View - Fig 01

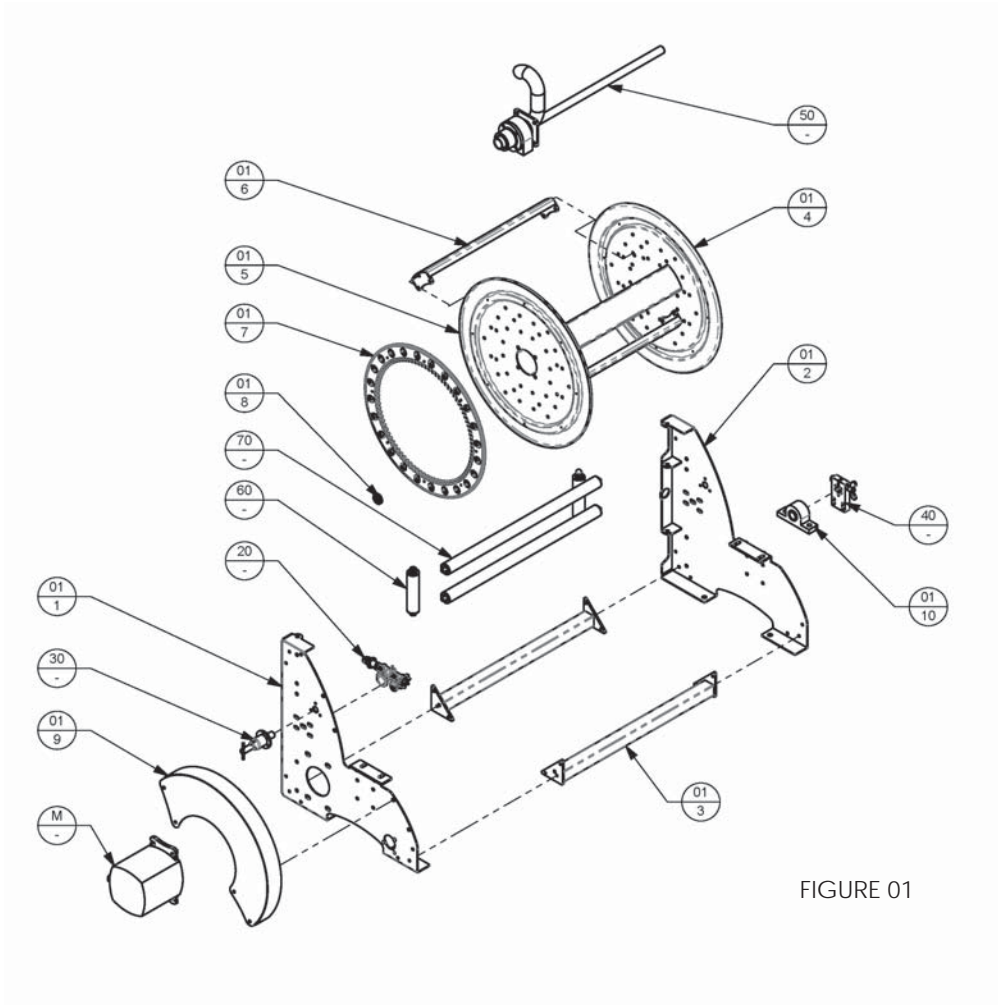

FIGURE 01

T Series Assembly Exploded View (Bevel Gear A) - Fig 20A

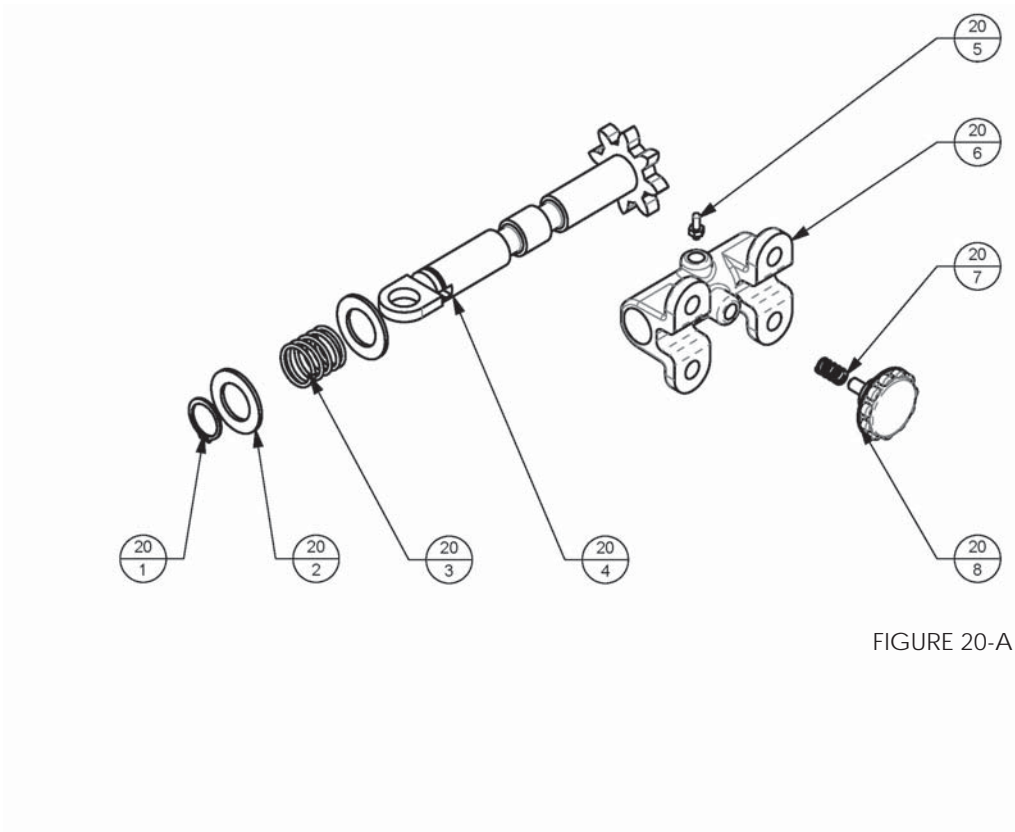

FIGURE 20-A

T Series Assembly Exploded View (Bevel Gear B) - Fig 20B

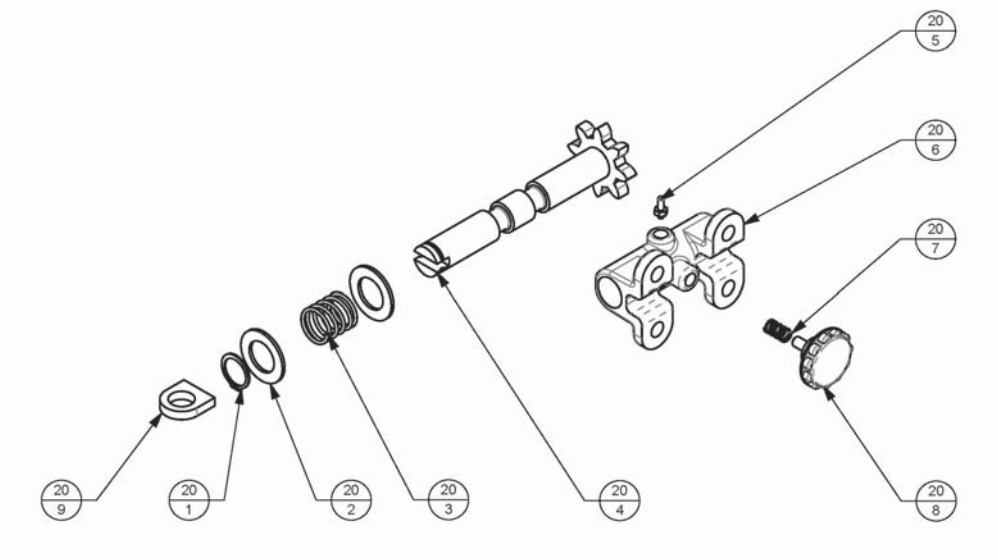

FIGURE 20-B

T Series Assembly Exploded View (Pin Lock) - Fig 30

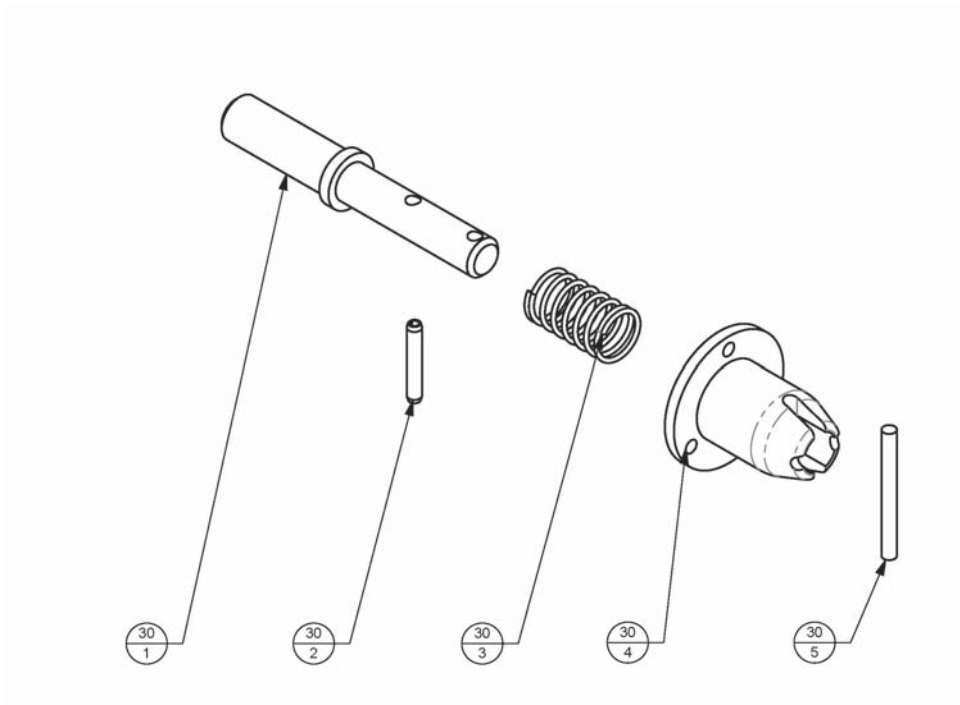

FIGURE 30

T Series Assembly Exploded View (Friction Brake) - Fig 40

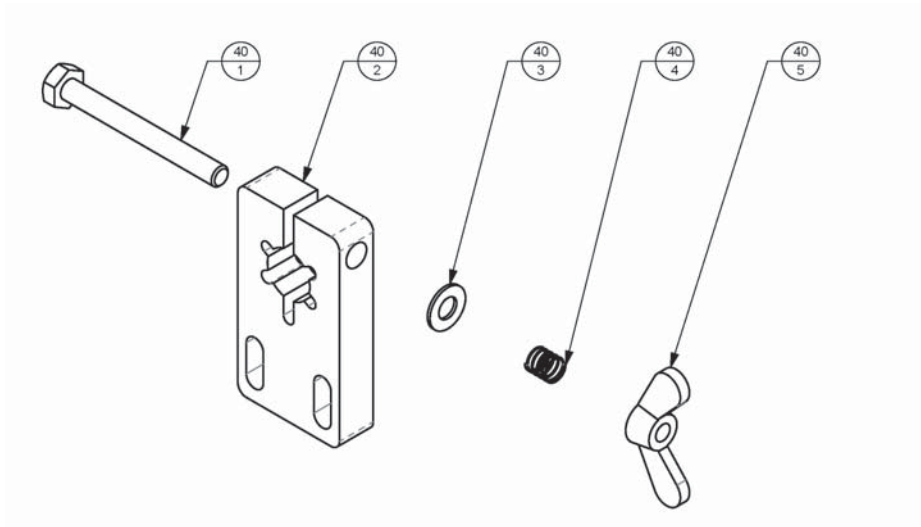

FIGURE 40

T Series Assembly Exploded View (Fluid Path) - Fig 50

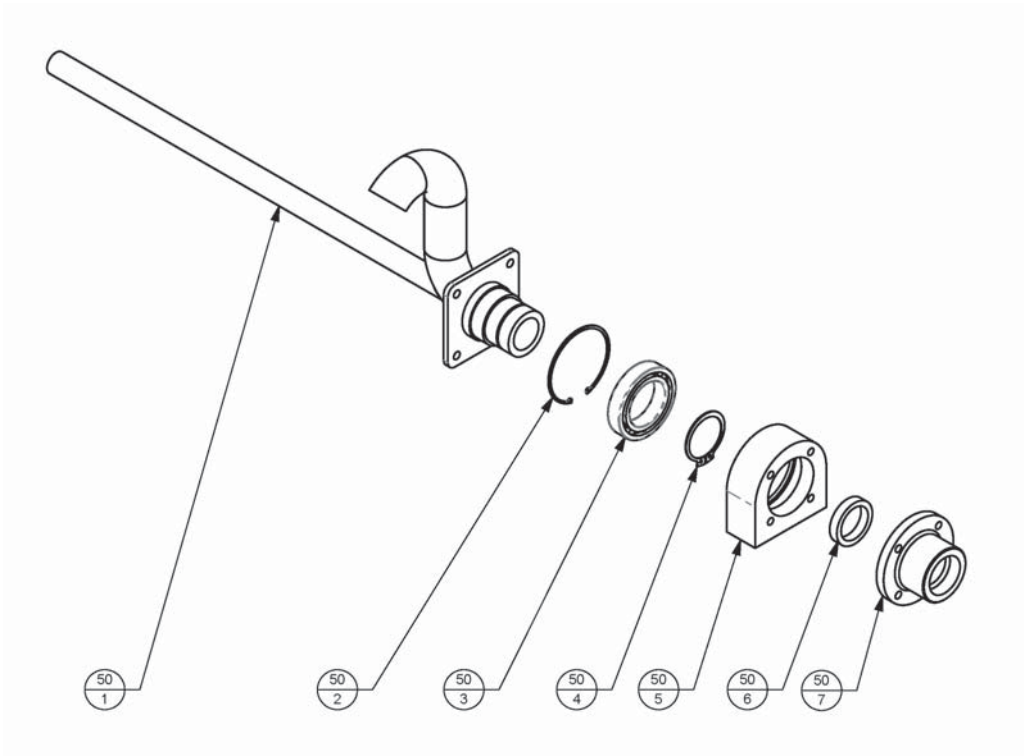

FIGURE 50

T, ST, C, LT Series Assembly Exploded View (Vertical Roller Guide) - Fig 60

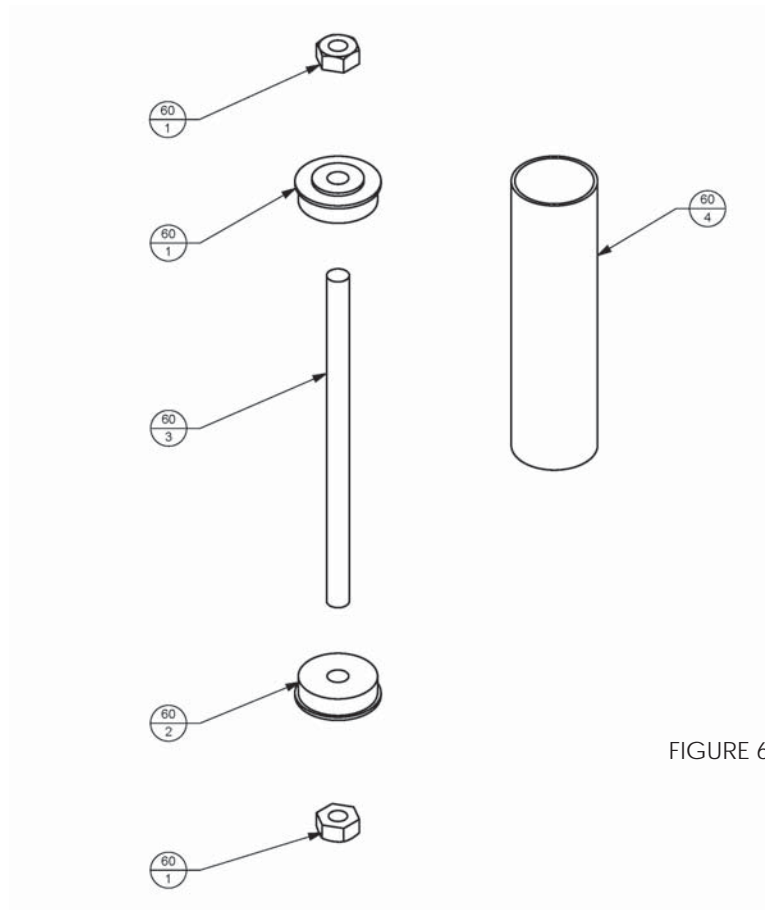

FIGURE 60

T Series Assembly Exploded View (Horizontal Roller Guide) - Fig 70

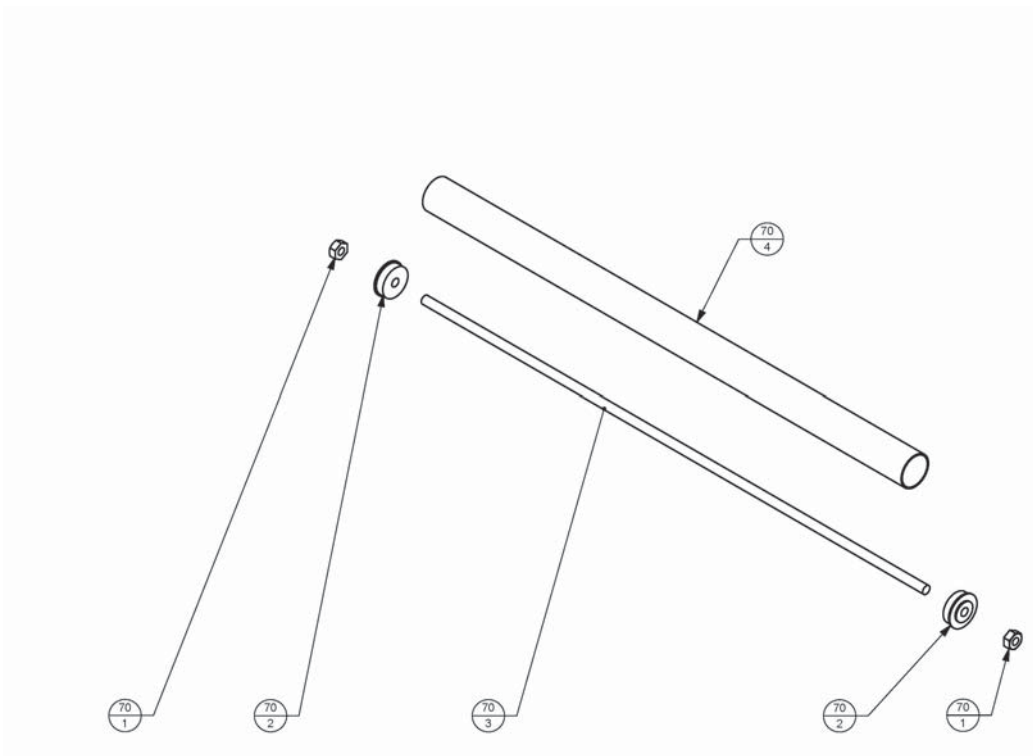

FIGURE 70

ST Series Assembly Exploded View (Spring Rewind) - Fig 70

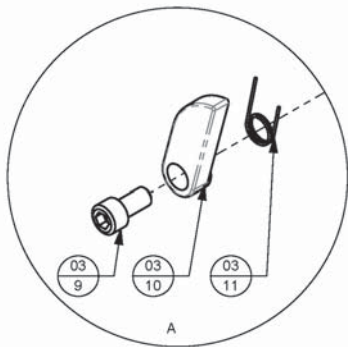
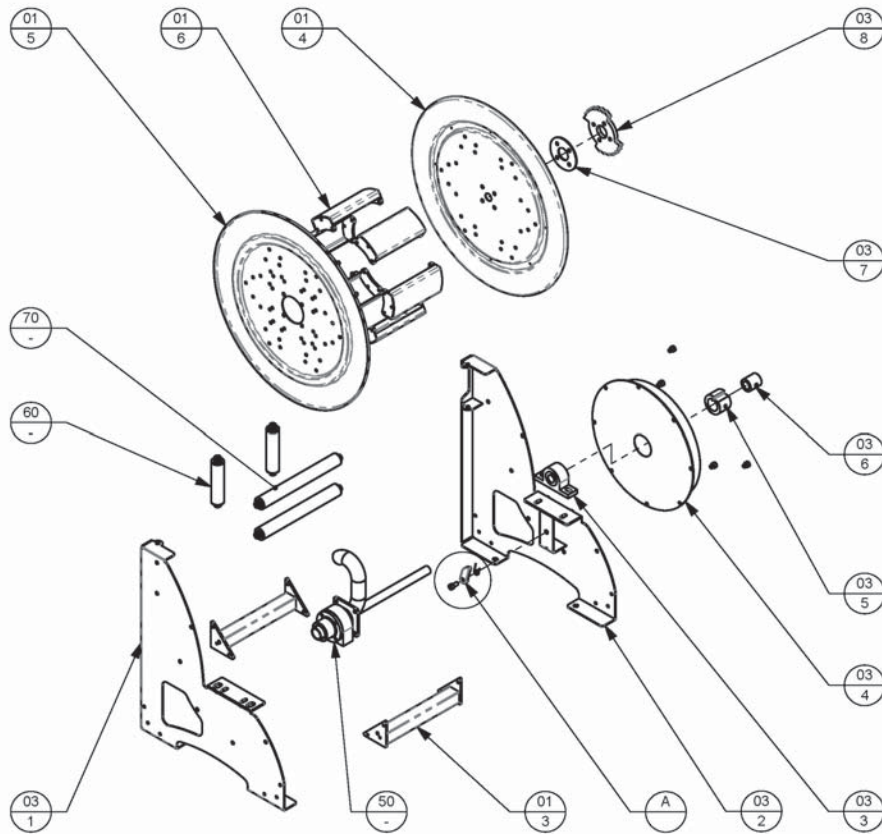

FIGURE 03

# Contact Us

## Head Office Australia

Postal address:

PO BOX 6463 BC  
Blacktown NSW 2148  
Australia

Phone

(61) 2 9621 8988

Email

[sales@recoila.com.au](mailto:sales@recoila.com.au)

Street address:

Unit 1/10 Melissa Place  
Kings Park NSW 2148  
Australia

Fax

(61) 2 9621 7688

Web

[www.recoila.com.au](http://www.recoila.com.au)

## New Zealand Warehouse & Distribution

Postal address:

PO BOX 101582  
North Shore Mail Centre  
North Shore City 0745  
New Zealand

Phone

(64) 9 4410177

Email

[sales@recoila.co.nz](mailto:sales@recoila.co.nz)

Street address:

Unit 1/A 93 Ellice Rd  
Glenfield  
North Shore City 0629  
New Zealand

Fax

(64) 9 4410178

Web

[www.recoila.co.nz](http://www.recoila.co.nz)

