



Recoila

HOSE AND CORD REELS

Catalogue T Series

Hose, Cord & Cable Reels



Engineered Confidence

www.recoila.com.au

About ReCoila

ReCoila® is a wholly Australian owned company with a manufacturing facility in the industrial precinct of Kings Park situated in the western region of Sydney.

ReCoila® has been manufacturing quality hose reels for some 30 years servicing both domestic and international markets. Our range of reels includes Composite spring rewind hose and cable reels, fabricated steel reels in powder coated finish, stainless steel and aluminium with hand crank, and motorized versions.

ReCoila® as a manufacturer offers an extensive range of Australian made hose cord and cable reels, this range is supplemented with selected products from renowned quality manufacturers in the USA and Europe to bring you the most comprehensive range of hose, cord and cables reels.

Our stringent in house testing ensures all products meet the quality that you expect from ReCoila whether it be an Australian made reel or manufactured elsewhere and distributed by us. Our aim has always been to design and manufacture the best reels available at a cost effective price. We continue to lead the way in design, innovative ideas, functionality and reliability of our products and utilize state of the art manufacturing methods setting the standards for others to follow.

ReCoila® is committed to continued quality and engineering excellence balanced with price competitiveness to supply users with the best reels available.

Hence we proudly say

“Engineered Confidence”



POSTAL ADDRESS

Po Box 6463 BC, Blacktown NSW 2148, Australia

FACTORY ADDRESS

Unit 1/10 Melissa Place, Kings Park NSW 2148, Australia

Engineered Confidence

ReCoila® is Industry's choice to a safer, more productive, effective work place environment. The technical data and information contained within this catalogue has been designed to explain and highlight the features and benefits of the latest Generations of ReCoila® hose, cord and cable reels.

Our goal is to help you understand these features which make us market leaders and separates our reels from the rest, real features, real benefits giving you the customer confidence that your decision to purchase a ReCoila® hose, cord or cable reel is indeed the right choice.

Quality, functionality and durability are the criteria Recoila demands in its reels because that is what our customers expect. We utilize the state of the art design and manufacturing principals to continue to be market leaders.

ReCoila® enjoys a global reputation for supplying reels that often exceed our customers expectations and we continue to strive for even greater engineering excellence combined with value for money"

Hence we proudly boast

“Engineered Confidence”



Why the demand for Recoila hose, cord and cable reels?

ReCoila[®] hose, cord and cable reels offer you an economical and quality solution that will improve your Safety record, improve Efficiencies, Increase Productivity and Reduce costly downtime.

The increasing demand for Hose, Cord and Cable REELS is being driven globally by work place Safety regulations and requirements, the need to reduce accidents, to protect workers and ultimately reduce insurance premiums for employers. Aside from increasing Safety, the use of ReCoila[®] reels will increase Efficiencies and Productivity through providing operators a more effective means of handling hoses, cords and cables in their workplace environment. Reduction in downtime and lower maintenance costs are an additional benefit of efficient hose management minimizing damage to hoses and cables using ReCoila[®] reels.



Over 3000 variations and models of Hose Reels, Cord Reels and Cable Reels

With such a huge range to choose from, ReCoila® can service your needs from spring rewind, hydraulic motor rewind, 12 and 24 VDC electric motor rewind, air motor rewind, hand crank and reduction drive hand crank hose reels. Hose lengths to 150 metres (500ft) and diameters up to 50mm (2") in standard configurations as well as custom designed hose reels and cable reels for special applications.

Application versions include air hose reels, water hose reels, fire hose reels, lubrication, chemical and fuel reels amongst many other types of medium transfer.

The best advice, best value and best service

ReCoila® provides you competitively priced hose and cable handling solutions based on engineering excellence ensuring quality products that perform. We offer qualified advice to ensure you receive the best product for your application at the best value and followed up with the best after sales service.

Custom Designed & Manufactured Facilities

ReCoila's® experience in designing and manufacturing hose and cable reels for some 25 years extends to custom designed and manufactured reels for all types of applications.

Refer to our web site www.recoila.com.au and our hose & cable reel request form to specify your reel requirement.



T Series

Heavy Duty Power Rewind Reels

Features & Benefits

ReCoila® T heavy duty power rewind hose and cable reels are design for application where reliability, longevity and strength is required. This range of reels are welded, fabricated of heavy gauge steel plate to ensure rigidity and strength.

Designed for applications such as:

- Lubrication
- Watering
- Fuel transfer
- High volume compressed air
- Food transfer
- Fire fighting

Drive options:

- Hand crank
- Bevel hand crank
- 12 VDC
- 24 VDC
- 110 VAC
- 240 VAC
- 415 VAC
- Hydraulic
- Pneumatic

Options construction materials

- Carbon steel
- Stainless steel 316
- Aluminium

- **Compact rugged design**
- **Heavy duty spring loaded pin lock**
- **Auxiliary bevel crank drives with disengaging drives**
- **High flow swivels and fluid paths**
- **Stainless steel roller guides with ball bearings**
- **Ball bearing main axel bearings**
- **Welded frame design**
- **Heavy duty roll spun flanges**
- **Stainless steel fasteners used where applicable**
- **Optional fluid path construction materials**
- **Optional pressure ratings and swivel configuration**
- **Right hand or Left hand configurations**

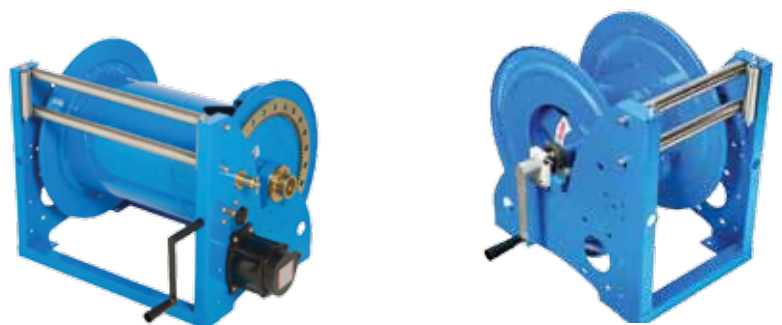

T Series Features & Benefits

Main axle

The main axle is machined from stainless steel to maintain strength and rigidity while preventing corrosion.

Bevel crank engage and disengage

Another unique feature of the T series is the ability to engage and disengage the bevel crank drive, this reduces wear on the drive system, noise and residual torque required to drive the traditionally engaged rewind system.



The crank connection point has been designed to allow the operator to rotate the crank drive from different angles.

Heavy duty spool

The T series has a heavy duty welded spool allowing the hose to be wound on charged or uncharged resisting the crushing effect of charging empty hoses on the reel.

Stainless steel roller guides with ball bearings

The T series roller guides are made from tough corrosion resistant stainless steel fitted with two ball bearing press fit bearings each end to allow smooth friction free operation.

Welded frame

The design and construction of the welded frame offers superior strength and rigidity.

Fluid paths and swivels

Full flow high volume 1-1/2" fluid paths are standard on all T series reels. Other fluid paths



such as 2" and 3" are available on those respective models that are designed for 2" and 3" hose. Standard working pressures of 800 psi can be increased up to 10,000 psi on request.

Construction materials

The T series construction and fluid paths are available in stainless steel, Mild steel, Aluminium, H.D.P.E or a combination of the above.

Finishes

Again the T series is finished in a high quality baked on powder coat in a stylish Blaze Blue, however on placement of order you can select your own specific colour if required.

Friction brakes

The stand alone friction brake allows the operator to preset sufficient friction preventing over spooling. Combination bevel crank friction brakes forces the operators to continually adjust and readjust the friction brake to operate the bevel crank rewind.

Direct drive spur gear

The T series uses a direct drive method of gear to gear reducing maintenance costs when servicing chain drive system.

Fluid path risers

The unique design of the T series fluid path allows for a gradual tangent between the hose and the fluid path reducing hose stress and flow restrictions at the connection point while keeping the layering neat and tidy.

Configurations

The T series can be configured LH or RH drive, LH or RH inlet, Top wind and bottom wind allowing us to offer any number of configurations to suit your applications.

Fasteners

All T series reels are furnished with high quality, high strength shake-proof stainless steel fasteners to ensure ease of maintenance and corrosion resistance.

Rewind speeds

The T series rewind speeds have been designed to maintain acceptable and controlled rewinding of the hose while maintaining sufficient torque to rewind a fully charged hose.

Rewind methods

The T series reels are available with 12 - 24 VDC rewind motors, 110 - 240 VAC rewind motors, Hydraulic rewind, Pneumatic rewind, reduction drive bevel crank and hand crank options.



Transfer / Refueling / Fire Fighting Industrials Reels

Rewind Systems	Options	Construction Materials
Hand crank	Friction brake	Carbon Steel
Bevel crank	Pin lock	Aluminium
12 VDC	Colour code	Stainless steel
24 VDC	Aux bevel crank	
110 VAC	RH & LH drives	
240 VAC / 415 VAC	Top or bottom wind	
Hydraulic		
Pneumatic		

Operating pressure from - 24Hg to 10,000 PSI. The following models are listed for your convenience other variations available on request. The listed capacities are based on a standard drum diameter of 278-mm OD.

Hose capacity metres Based on a 280mm OD spool				Dimensions – mm approximate			
Model	1/2"	3/4"	1"	A	B	C	G
T580150	45	20	10	620	660	275	Hand crank
T580200	60	30	18	620	660	325	C + 170
T580300	100	45	25	620	660	425	Bevel Crank
T580350	115	50	30	620	660	475	C + 75
T580400	130	60	35	620	660	525	12/24 VDC
T580500	170	70	40	620	660	625	C + 178
T580550	185	80	45	620	660	675	Hydraulic
T580600	200	90	55	620	660	725	C + 172
T580650	225	95	60	620	660	775	Pneumatic
T640150	60	28	15	680	700	275	C + 110
T640200	90	40	25	680	700	325	
T640300	150	60	35	680	700	425	
T640350	170	70	40	680	700	525	
T640400	190	80	55	680	700	575	
T640450	230	90	60	680	700	625	
T640500	0	100	65	680	700	675	
T640550	0	110	70	680	700	725	
T640600	0	125	80	680	700	772	
T640650	0	130	85	680	700	775	
T780200	0	65	45	800	820	325	
T780300	0	100	65	800	820	425	
T780350	0	110	75	800	820	475	
T780400	0	130	95	800	820	525	
T780450	0	145	100	800	820	575	
T780500	0	165	115	800	820	625	
T780550	0	180	125	800	820	675	
T780600	0	200	145	800	820	725	

Transfer / Refueling / Industrials Reels

Operating pressure -24Hg to 10,000 PSI

Rewind Systems	Options	Construction Materials
Hand crank	Friction brake	Carbon Steel
Bevel crank	Pin lock	Aluminium
12 VDC	Colour code	Stainless steel
24 VDC	Aux bevel crank	
110 VAC	RH & LH drives	
240 VAC / 415 VAC	Top or bottom wind	
Hydraulic		
Pneumatic		

The following models are listed for your convenience other variations available on request. The listed capacities are based on a standard drum diameter of 405-mm OD.

Model	Hose capacity metres Based on a 410mm OD spool		Dimensions – mm approximate				
	1-1/2"	2"	A	B	C	G	
T640300	15	15	680	700	425		Hand crank
T640400	20	8	680	700	525		C + 170
T640500	30	10	680	700	625		Bevel Crank
T640600	35	12	680	700	725		C + 75
T640700	40	15	680	700	825		12/24 VDC
T780300	25	65	800	820	425		C + 178
T780400	35	20	800	820	525		Hydraulic
T780500	45	25	800	820	625		C + 172
T780600	60	30	800	820	725		Pneumatic
T780700	70	35	800	820	825		C + 110
T780800	80	40	800	820	925		

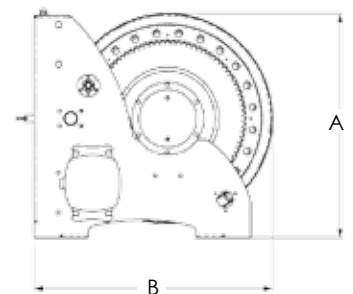
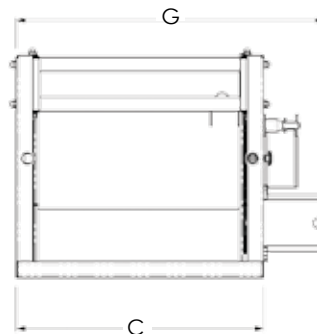

T Series Dimensions

Contact Us

Postal address:
PO BOX 6463 BC
Blacktown NSW 2148
Australia

Street address:
Unit 1/10 Melissa Place
Kings Park NSW 2148
Australia

Phone:
(61) 2 9621 8988

Fax:
(61) 2 9621 7688

Email:
sales@recoila.com.au

Web
www.recoila.com.au

Global Distribution

