



ReCoila

HOSE AND CORD REELS

for Fire Fighters



Engineered Confidence

Cover image kindly provided by the NSW Rural Fire Service designed Category 11 4x4 Village Pumper

T Series

Heavy Duty Power Rewind Reels



Low profile hot dipped galvanized hose reels designed for the tightest of compartments.



Hose reels fabricated in Aluminium with stainless steel wetted parts for maximum weight loss and corrosion resistance.

This reel is bottom wind allowing it to be mounted in an under body fashion.



Hose reel fitted with layering rewind systems.

These systems free up operators allowing them to attend to more important task than feeding the hose on and off the reel.



Hose reels fitted with swivel bases to allow up to 270 degrees of rotation.

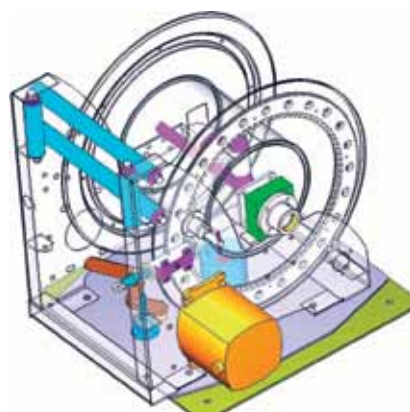

Custom build and designed hose reels to suit your requirements.

When a standard model is not available or an aged unit needs replacement and can not be sourced anymore we offer a full in house design and build service.

Drive options

- Hand crank
- Bevel hand crank
- 12 VDC
- 24 VDC
- 110 VAC
- 240 VAC
- 415 VAC
- Hydraulic
- Pneumatic

Construction Material

- Steel
- Aluminium
- Stainless Steel

Finish

- Powder coat
- Hot dip galvanised

Working Pressure

- 800 PSI STD
- 10,000 PSI

Hose length

- 0 - 300 m

Hose diameters

- 1/2" - 2'

Mediums

- Water
- Foam
- CO₂
- Hydraulic Fluids

T Series Features & Benefits

Main axle

The main axle is machined from stainless steel to maintain strength and rigidity while preventing corrosion.

Bevel crank engage and disengage

Another unique feature of the T series is the ability to engage and disengage the bevel crank drive, this reduces wear on the drive system, noise and residual torque required to drive the traditionally engaged rewind system. The crank connection point has



been designed to allow the operator to rotate the crank drive from different angles.

Heavy duty spool

The T series has a heavy duty welded spool allowing the hose to be wound on charged or uncharged resisting the crushing effect of charging empty hoses on the reel.

Stainless steel roller guides with ball bearings

The T series roller guides are made from tough corrosion resistant stainless steel fitted with two ball bearing press fit bearings each end to allow smooth friction free operation.



Welded frame

The design and construction of the welded frame offers superior strength and rigidity.

Fluid paths and swivels

Full flow high volume 1-1/2" fluid paths are standard on all T series reels. Other fluid paths such as 2" and 3" are available on those respective models that are designed for 2" and 3" hose. Standard



working pressures of 800 psi can be increased up to 10,000 psi on request.

Construction materials

The T series construction and fluid paths are available in stainless steel, Mild steel, Aluminium, H.D.P.E or a combination of the above.

Finishes

Again the T series is finished in a high quality baked on powder coat as well as hot dip galvanised.

Friction brakes

The stand alone friction brake allows the operator to preset sufficient friction preventing over spooling. Combination bevel crank friction brakes forces the operators to continually adjust and readjust the friction brake to operate the bevel crank rewind.

Direct drive spur gear

The T series uses a direct drive method of gear to gear reducing maintenance costs when servicing chain drive system.

Fluid path risers

The unique design of the T series fluid path allows for a gradual tangent between the hose and the fluid path reducing hose stress and flow restrictions at the connection point while keeping the layering neat and tidy.

Configurations

The T series can be configured LH or RH drive, LH or RH inlet,



Top wind and bottom wind allowing us to offer any number of configurations to suit your applications.

Fasteners

All T series reels are furnished with high quality, high strength shake-proof stainless steel fasteners to ensure ease of maintenance and corrosion resistance.

Rewind speeds

The T series rewind speeds have been designed to maintain acceptable and controlled rewinding of the hose while maintaining sufficient torque to rewind a fully charged hose.

Rewind methods

The T series reels are available with 12 - 24 VDC rewind motors, 110 - 240 VAC rewind motors, Hydraulic rewind, Pneumatic rewind, reduction drive bevel crank and hand crank options.



Phone:
(61) 2 9621 8988

Fax:
(61) 2 9621 7688

Email:
sales@recoila.com.au

Web:
www.recoila.com.au

Postal address:
PO BOX 6463 BC
Blacktown NSW 2148
Australia

Street address:
Unit 1/10 Melissa Place
Kings Park NSW 2148
Australia

Contact Us