



# ReCoila

HOSE AND CORD REELS

## Operation and Service Manual for ReCoila® Self-Retracting hose, cord & cable Reels



ReCoila® GEN III

**Engineered Confidence**

[www.recoila.com.au](http://www.recoila.com.au)  
[www.recoila.co.nz](http://www.recoila.co.nz)

For Models after 1 June 2004

## Overview

The following operation, service and repair manual has been designed to give the operator/user a full understanding of the operational aspects of the hose and cable reels as well as being a supplement to our factory service and maintenance training course.

The basic principle of each reel is the same and the repair or service is carried out in the same manner from one model to the next, however certain models require higher levels of technical knowledge. These reels are listed separately and so are their respective parts breakdown.

## **Models covered by this manual - GEN III Series**

This manual covers the following series of hose reels. Variations of each series or model may not be specifically listed such as stainless steel versions or a fully optioned reel, however, the procedures remain the same throughout the range for making repairs and service work as well as installation.

If you feel that the information does not reflect your specific hose reel please contact our customer service department for clarification.

### **Self Retracting Hose and Cable Reels**

**Air Reels**

**Water Reels**

**Oxygen and Fuel Gas Reels**

**Oil Reels**

**Grease Reels**

**Inert Gas Reels**

**Food Grated Reels**

**Electrical Extension Cord Reels**

**Portable Light Reels**

**Forklift Recharging Reels**

**Hot Wash Down Reels**

**Weedicide Pesticide Reels**

Other models available on request please contact your nearest distributor.

# Table of Contents

|   |    |
|---|----|
| About us  | 5  |
| <b>Quality and Certification</b>                  |    |
| CE Declaration of Conformity                      | 6  |
| Supplier Declaration of Conformity                | 7  |
| Listing of explanation symbols                    | 8  |
| ReCoila <sup>®</sup> 's quality statement         | 9  |
| Terms and conditions of warranty                  | 10 |
| Procedure for making warranty claims              | 11 |
| Procedure for returning goods for repair          | 12 |
| <b>Installation instructions</b>                  |    |
| Pre-Inspection                                    | 13 |
| Connection of the inlet hose                      | 13 |
| Mounting the reel                                 | 14 |
| Fitting optional mounting brackets                | 15 |
| How to use the reel                               | 16 |
| <b>Maintenance</b>                                |    |
| Inserting the locking pin service tool            | 17 |
| Checking for leaks                                | 18 |
| Checking for hose defects                         | 18 |
| Servicing or replacing seals, O-rings & swivels   | 19 |
| Adding or removing tension                        | 20 |
| <b>Repair procedures</b>                          |    |
| Replacing mouth guard                             | 22 |
| Replacing swivels, slip-rings and O-rings / seals | 22 |
| Replacing hoses or cables                         | 24 |
| Replacing the tension locking system              | 25 |
| Replacing the outer cases                         | 26 |
| Replacing a broken spring                         | 27 |
| <b>Spare parts breakdowns</b>                     |    |
| General parts breakdown                           | 28 |
| Swivel parts breakdown                            | 29 |
| Swivel parts Oxygen and Fuel gases                | 30 |
| Swivel parts high pressure                        | 31 |
| Slip ring parts                                   | 32 |
| Tension locking system breakdown                  | 33 |
| Spring and drum assembly                          | 33 |
| Numerical part number listing                     | 34 |

## About Us

ReCoila® is a wholly Australian owned company with a manufacturing facility in the industrial precinct of Kings Park situated in the western region of Sydney.

ReCoila® has been manufacturing quality hose reels for some 30 years, servicing both domestic and international markets.

Our range of reels includes composite spring rewind hose and cable reels, fabricated steel reels in powder coated finish, stainless steel and aluminium with hand crank, and motorised versions.

ReCoila® as a manufacturer, offers an extensive range of Australian made hose cord and cable reels, this range is supplemented with selected products from renowned quality manufacturers in the USA and Europe to bring you the most comprehensive range of hose, cord and cables reels.

Our stringent in house testing ensures all products meet the quality that you expect from ReCoila®, whether it be an Australian made reel or manufactured elsewhere and distributed by us. Our aim has always been to design and manufacture the best reels available at a cost effective price.

We continue to lead the way in design, innovative ideas, functionality and reliability of our products and utilise state of the art manufacturing methods, setting the standards for others to follow.

ReCoila® is committed to continued quality and engineering excellence balanced with price competitiveness to supply users with the best reels available.

Hence we proudly say

**“Engineered Confidence”**

# CE Declaration of Conformity

We,

Strata Group (Aust) Pty Ltd

Unit 1/10 Melissa Place

Kings Park NSW 2148

Australia

Phone: (61) 2 9621 8988

Fax: (61) 2 9621 7688

Declare under our sole responsibility that the product ReCoila<sup>®</sup> Spring rewind hose cord and cable reels, to which this declaration relates, is in conformity with the following documents.

Strata design specifications and acceptance criteria following the provision of 98/37EC (Machinery Directive).

The technical construction file is maintained at the following addresses:

1.

Strata Group (Aust) Pty Ltd

Unit 1/10 Melissa Place

Kings Park

NSW 2148

Australia

Phone: (61) 2 9621 8988

Fax: (61) 2 9621 7688

2.

Reelcare

Unit L Tyson Courtyard

Weldon South Industrial Estate

Corby Northamptonshire NN18 8AZ

United Kingdom

Phone: (44) 1536 407001

Fax: (44) 1536 261491

## Supplier Declaration of Conformity (SDoC)

In accordance with ISO/IEC 17050-1:2004

|  |                                       |   |                                       |
|--|---------------------------------------|---|---------------------------------------|
| <b>SDoC identification Number<sup>1</sup> -</b>  |                                       |   |                                       |
| <b>Issuer details</b>  |                                       |   |                                       |
| <b>Name<sup>2</sup></b> (of New Zealand manufacturer or importer)  |                                       | <b>Contact Address</b>  |                                       |
| <b>RECOILA NZ PTY LTD</b>  |                                       | <b>UNIT 1A 93 ELLICE ROAD<br/>GLENFIELD, NORTH SHORE CITY, 0629<br/>NEW ZEALAND</b> |                                       |
| New Zealand Company Number (if applicable)   |                                       |   |                                       |
| <b>Telephone</b>   | <b>Fax</b>                            | <b>Email address</b>  |                                       |
| <b>9441 0177</b>   | <b>9441 0178</b>                      | <b>sales@recoila.co.nz</b>  |                                       |
| <b>Medium Risk Article – Details<sup>3</sup> (Product name, type, rating, brand, model, batch numbers, and serial numbers, as applicable)</b>                          |                                       |   |                                       |
| <b>EL2402010</b>   |                                       | <b>L24032610</b>  |                                       |
| <b>EL2402015</b>   |                                       |   |                                       |
| <b>EE2401210</b>   |                                       |   |                                       |
| <b>EE2401215</b>   |                                       |   |                                       |
| <b>The Medium Risk Article, listed above, fully complies with the cited standard(s), as listed:-</b>   |                                       |   |                                       |
| <b>Standard number &amp; issue year:-</b><br><b>AS/NZS 3105:1993</b>   |                                       | <b>Standard number &amp; issue year:-</b><br><b>AS/NZS3100:1994</b>                 |                                       |
| <b>Standard Title:-</b><br><b>ELECTRICAL PORTABLE OUTLET<br/>DEVICES</b>   |                                       | <b>Standard Title:-</b>   |                                       |
| <b>Edition / Amendment status:-</b><br><b>.1</b>   | <b>AS/NZS ZZ modified</b><br><b>N</b> | <b>Edition / Amendment status:-</b><br><b>.1</b>                                    | <b>AS/NZS ZZ modified</b><br><b>N</b> |
| <b>Or complies with the Conformity Cooperation Agreement - No</b>  |                                       |   |                                       |
| <b>Names and addresses of any testing organisation or body</b>   |                                       |   |                                       |
| <b>Name(s)</b>   |                                       | <b>Address(es)</b>  |                                       |
| <b>TESTING &amp; CERTIFICATION<br/>AUSTRALIA</b>   |                                       | <b>AUSTRALIA</b>  |                                       |
| <b>DEPARTMENT OF ENERGY</b>  |                                       | <b>AUSTRALIA</b>  |                                       |
| <b>Reference to relevant test reports/certification, and issue date of the reports/certification, that show how compliance is achieved:-</b>                           |                                       |   |                                       |
| <b>Standard(s) or document(s) used, to show how compliance with cited standard is achieved:-</b>   |                                       | <b>Report/Certification or Document reference N°(s):-</b>                           | <b>Issue date(s)</b>                  |
| <b>AS/NZS3100:1994</b>   |                                       | <b>N14520</b>   | <b>18/9/95</b>                        |
| <b>AS/NZS3105:1993</b>   |                                       |   |                                       |
| <b>Reference to any management systems involved:-</b><br><b>NATA No. 62</b>  |                                       |   |                                       |
| <b>Additional<sup>4</sup> information</b><br><b>100% TEST &amp; TAG PROCEDURE</b>  |                                       |   |                                       |
| <b>Declaration</b>   |                                       |   |                                       |
| I hereby declare that the above specified fittings or electrical appliances comply with the requirements of Regulation 83 of the Electricity (Safety) Regulations 2010 |                                       | <b>Signed for and on behalf of:</b><br><b>RECOILA NZ PTY LTD</b>                    |                                       |
| <b>Issuer Identification:</b><br>(as affixed to the article).  |                                       | <b>Names &amp; position, as authorized by the issuer</b>                            |                                       |
| <div style="border: 1px solid black; width: 100%; height: 100%;"></div>  |                                       | <b>MICHAEL PAWSON</b>   |                                       |
|  |                                       | <b>Signature</b>  | <b>Date 1/12/10</b>                   |

<sup>1</sup> Every declaration of conformity should be uniquely identified.

<sup>2</sup> The responsible issuer must be unequivocally specified.

<sup>3</sup> The "Article" must be unequivocally described so that the declaration of conformity may be related to the article in question. For mass-produced products, it is not necessary to give individual serial numbers. Where variants of an article are to be covered, these must be detailed.

## List of precaution symbols



Means Warning. Watch out! There are possible hazards with this procedure! Possible hazards are shown by this warning symbol.



Means Warning. Moving parts, keep away from moving parts and pinch points.

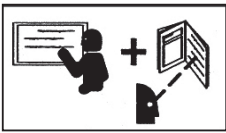

Means consult the service centre or become trained and read the service manual.

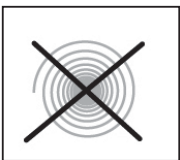

Means Warning. Item under tension, this area contains a tensioned spring.



Means Warning. Do not remove fasteners or attempt to service without contacting a service centre or becoming fully trained on the service and repair of hose reels.



Means Warning. Never let the hose or cable rewind uncontrolled.

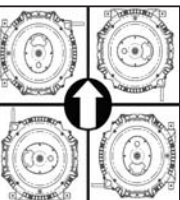

Means all positional locking system.



Means ensure you have full knowledge of the service or repair task being carried out. Possible hazards.

**Note: Please refer to your local authority for rules and regulations on the safe use of compressed liquids, gases and fuel gases.**

## **Strata Group (Aust) Pty Ltd's Quality Statement**

All ReCoila<sup>®</sup> Self-Retracting hose and cable reels are built with quality in mind. Our in-house quality system requires us to check raw materials and sub-contracted components to ensure they meet the standard of engineering we require in order to offer the best possible product on the market.

During the four stages of manufacturing each sub-assembly is checked to ensure functionality and dimensional correctness. Specific components such as swivels and slip-rings are checked at the sub-assembly stage and during final assembly to ensure they pass low pressure and high pressure tests. Slip-rings are checked for electrical continuity and earth leakage.

A final assembly check is carried out before packing to ensure the reel retracts correctly and the locking system is functioning correctly.

Our in-house quality system is backed by our warranty should undetected or unforeseen failures occur.

## **Terms and Conditions of Warranty**

### **The one year Limited Warranty Statement**

Strata Group (Aust) Pty Ltd affirms its product confidence with the following warranty.

All products manufactured by Strata Group (Aust) Pty Ltd are warranted to be free of defects in material and workmanship for Twelve (12) months from the date of invoice.

Strata Group (Aust) Pty Ltd's liability shall be limited to repair or replacement of defective material within the warranty period when returned freight paid to its plant or service depot designated by Strata Group (Aust) Pty Ltd.

The warranty does not cover damage caused by accident, misuse, use in applications other than for which the reel was designed, abuse or faulty installation or normal wear and tear. Strata Group (Aust) Pty Ltd products must be installed and maintained in compliance with the manual of instructions furnished with each reel.

### **Extended five year Limited Warranty**

The listed items have an extended five (5) year limited warranty

- Swivel component - sleeve and shaft.

### **Extended two year Limited Warranty**

The listed items have an extended Two (2) year limited warranty

- Spring and Plastic components.

### **The one and two year Warranty does not include the following:**

**Hose** - these are warranted by the respective hose manufacturers.

**O-rings** - are limited to three (3) months.

# Procedure for Making Warranty Claims

## Reels sold in Australia

Should you consider that the failure of the item is subject to warranty please follow the listed procedures.

## R.G.A. (Returned Goods Authority)

You are required to obtain an R.G.A. This can be obtained by phoning the Strata Group (Aust) Pty Ltd sales desk. Providing sufficient information is given an R.G.A. will be issued. The number must be clearly marked on the item. Goods returned without an R.G.A. will not be accepted from the carrier and will be returned by the same.

## Proof of date of sale/purchase

Proof of sale or of purchase is required and you need to send proof of date of sale or purchase with the item in question. Copies of invoices or sales dockets are considered sufficient proof.

## Full and complete contact details

Your complete contact details must be included with the item in question.

## Freight and method of return

The items are to be returned to the place of purchase, freight paid. Strata Group (Aust) Pty Ltd will pay for freight from the place of purchase to its nominated plant or service centre. No goods will be accepted at these nominated places, receiver to pay.

Providing that the item being returned is considered to be under warranty and our technicians confirm this on inspection, Strata Group (Aust) Pty Ltd will make the necessary repairs and return the item free of charge.

If the item is found to be faulty due to a non warrantable fault the item will be quoted for repair and freight will be charged both ways unless the customer has nominated their own freighter, then freight will be charged for the initial return to us.

Goods not found to be faulty under warranty, please refer to service and repair terms and conditions.

**Countries outside of Australia refer to your nearest distributor or the place of purchase.**

## **Procedure for Returning Items for Service or Repair**

### **For reels sold within Australia**

The following procedure covers items being returned for service or repair not covered by warranty.

### **R.G.A. (Returned Goods Authority)**

You are required to obtain an R.G.A. This can be obtained by phoning Strata Group(Aust) Pty Ltd sales desk. Providing sufficient information is provided by you, an R.G.A. will be issued. The number must be clearly marked on the item. Goods returned without an R.G.A. will not be accepted from the carrier and will be returned by the same.

### **Customer order number**

You are required to supply an official purchase order number for the repair which is to be returned with the item or faxed through to the service centre. For non account customers (such as an end-user) returning goods, you will be required to confirm some type of payment method such as credit card. Items returned without an accompanying purchase order or confirmed method of payment will not be quoted until such time that these details have been received.

### **Full and complete contact details**

Your complete contact details must be included with the item in question.

### **Freight and method of returned**

The items are to be shipped to a Strata Group (Aust) Pty Ltd nominated plant or service centre. No goods will be accepted at these nominated places with receiver to pay unless prior arrangement has been made to ship the item on Strata Group (Aust) Pty Ltd freight account whereby you will be invoiced freight cost at the going rate.

### **Quotation for the repair**

The items returned will be quoted for the cost of the repair and a copy will be faxed through to the customer for approval. The customer has seven days to confirm the repair.

If confirmation is not received within seven days the item will be returned by the nominated freight company or on Strata Group (Aust) Pty Ltd freight and a minimum service quotation fee will be charged. This quotation fee is \$25.00 plus any freight costs.

### **Sale or disposal of unclaimed/non confirmed items**

For items sent for warranty or repair that have not been collected or confirmed to be repaired or sent in without full customer details after a period of three months of receipt Strata Group (Aust) Pty Ltd reserves the right to dispose of, or sell any such items to recoup any costs, no claim against Strata Group (Aust) Pty Ltd will be recognised.

**For reels purchased outside of Australia refer to your nearest distributor or the place of purchase.**

## Pre-inspection

- Check the reel for shipping damages.
- Insure all parts are supplied as ordered.
- Record the Model Number and Serial Number for future reference.
- Complete the warranty registration form contained within this manual and return to ReCoila® affirming your year warranty period.
- We recommend that you check and re-lubricate bearing and moving parts as described in the maintenance section to ensure smooth reliable operation.

## Installation instructions

### Connection of the inlet (supply) hose/s

A flexible connection between the reel and the source of supply is required to prevent possible misalignment and binding. **Non flexible connections will void the warranty.** The pressure rating of the inlet hose must be equal to or greater than the rating of the reel.

**Always check with your local authorities for appropriate rules and regulations for safe use and handling of compressed gases, liquids and fuel gases.**

**Do not use lubricants or thread sealants on Oxygen connections unless such lubricants or sealants are approved by your local authorities for use with Oxygen.**

- Using the appropriate approved hose and fittings connect the supply line to the inlet connection of the reel.
- Ensure you use thread sealants where applicable and permitted.
- Never over-tighten or under-tighten fittings.
- Once connection has been made to the inlet of the reel, ensure you make or fit a connection to the outlet of the reel (the main hose) then turn the supply valve on slowly and check for leaks.

**Note: Please refer to your local authority for rules and regulations on the safe use of compressed liquids, gases and fuel gases.**

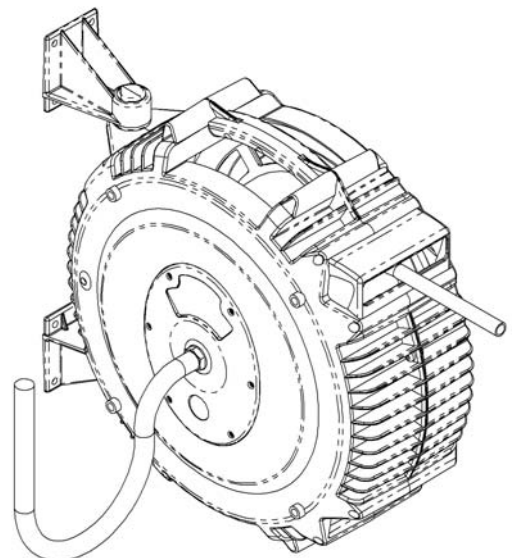

## Mounting the reel

All ReCoila<sup>®</sup> spring rewind hose reels are fitted with an all position locking system which allows the reel to operate in all positions (360 by 360 degrees). The reel is supplied as standard with a mounting system and brackets that allow ceiling mounting or wall mounting - an optional floor or under bench mount can be purchased for other mounting positions - see the following page for examples.

The optimum height for wall mounting is such that it allows the hose or cable to be pulled at an upward or downward angle of no more than approx. 15 degrees - angles exceeding this can create undue drag in operation and potentially cause premature wear to the mouth opening of the reel.

For wall mounting where heights above three metres are required, we suggest the use of the swivel mounting optional floor bracket. Bolt the bracket to the wall and fix the reel in position as you would for ceiling mounting – see example on the following page.

**Note: When putting reel into bracket do not allow reel to hang freely from bottom bracket. Hold in place.**

Typical mounting

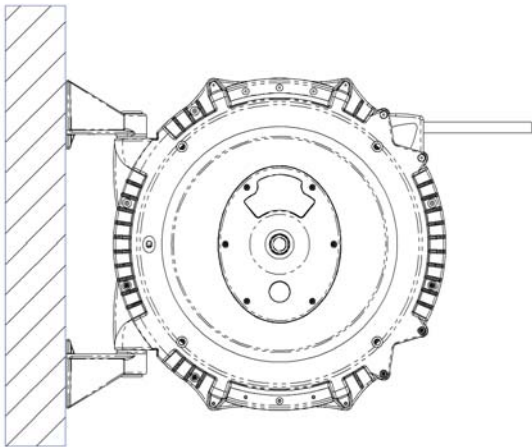

Ceiling mounting

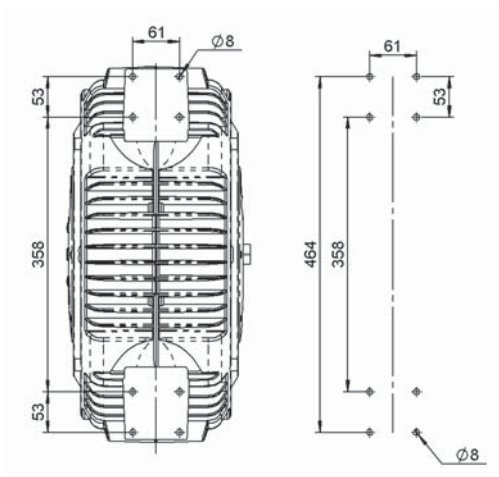
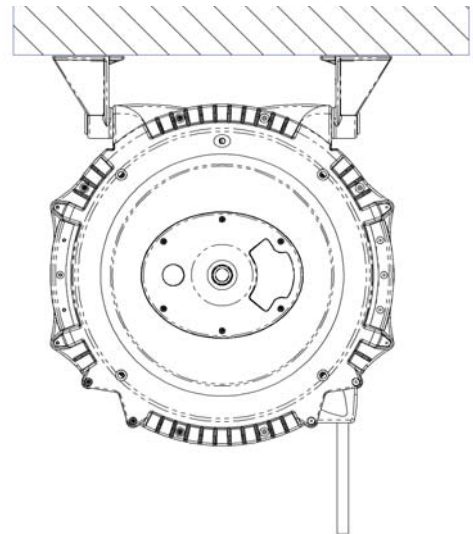

**Note: The orientation of the wall brackets are important, please follow drawings**

# Fitting optional mounting brackets

Optional extra mounting brackets are available such as, fixed floor mounting where you do not require the reel to swivel, or extra high wall mounting where you require the reel to be mounted high up on a wall, or swivel floor mounted and under bench mounting.

## Swivel floor mount

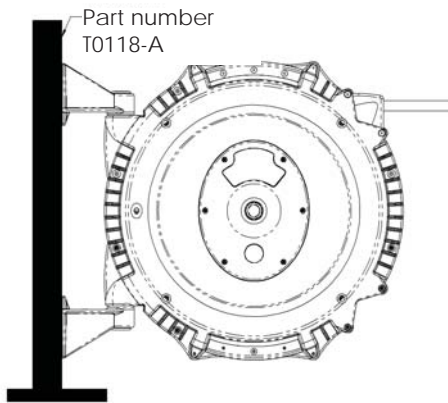

Typical extra high wall mount using the Swivel floor mounting bracket

## Fixed floor mount

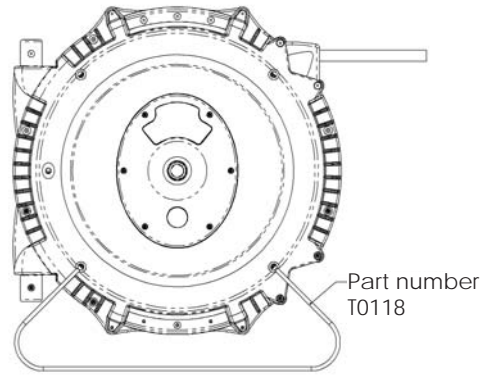

Under bench mounting using the fixed floor mounting bracket

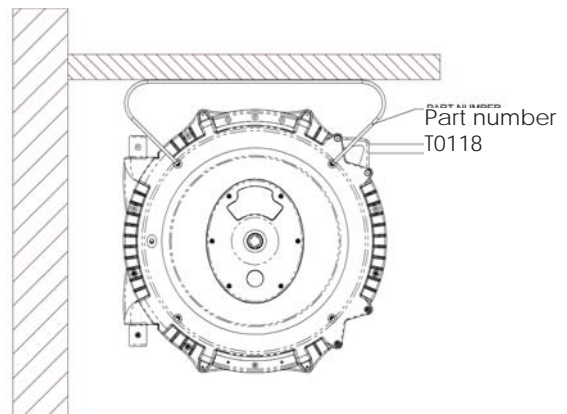
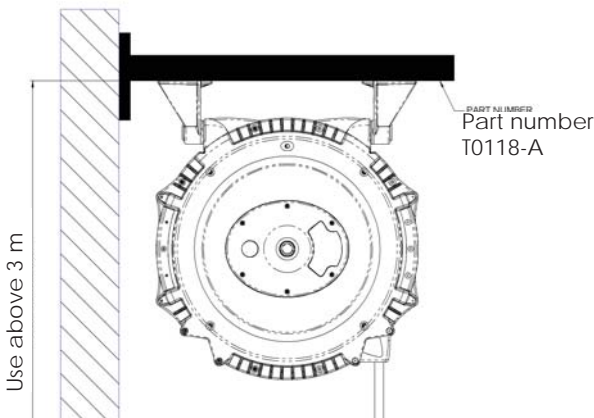

**Important:** When mounting the reel, do not leave the reel hanging unsupported in one mounting bracket whilst reaching for fasteners or tools. Leaving the reel hanging from one bracket places unnecessary stress on the bottom boss, and may cause the boss to fail immediately. If it does not break immediately, the boss can be severely weakened and fail some weeks later during normal operation.

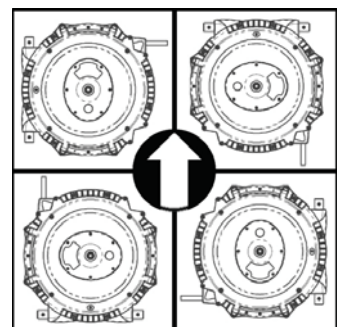
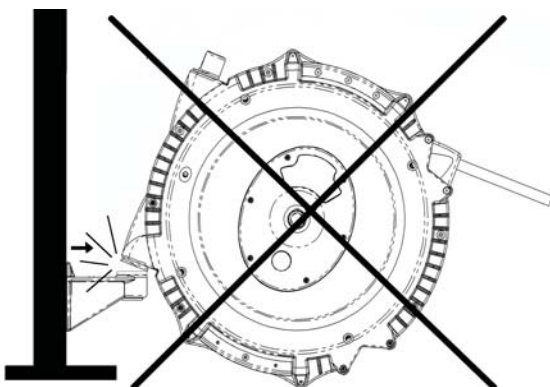

## How to use the reel

Once you have mounted your reel and made the inlet connection you are ready for operation. In order to familiarise yourself with the function of the reel, stand as close as possible to the reel, pulling the hose slowly - out, you will note a clicking noise. This is the locking pawl running over the locking teeth or ratchet teeth.

As soon as you hear this noise, stop pulling and allow the hose to retract a little and it will lock in position. If it won't lock allow the hose to retract back further then pull it again slowly, until you hear the first one or two clicks. Stop pulling and allow the hose to retract a small amount and it will lock.

Now pull it out some more until you hear the next set of clicks and repeat the locking process. The hose will lock at approx. every three feet (one metre) increments but only after you have been pulling it with an outward movement. The locking system is designed so the hose will never lock when rewinding it.

Once you are familiar with the system you won't need to listen for the locking clicks as you will automatically know when and where it will lock.

Never let the hose fly back uncontrolled. This can cause damage to property or person. Always keep a firm hold of the hose as it is retracting back into the reel.

To rewind the hose pull it out about 1ft or 300 mm and then allow it to retract back whilst holding the hose. If you want to stop the rewinding and lock it in position again, pull some hose out until you hear the clicking and allow it to retract a little, locking the hose in position.

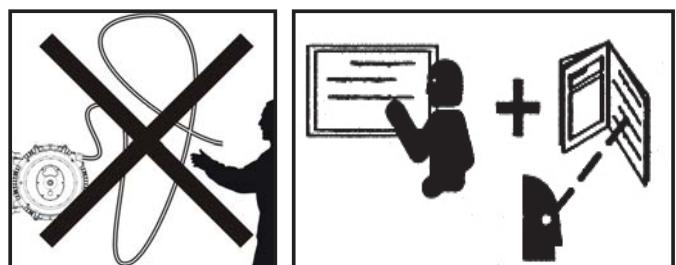

# Maintenance section

## Inserting the locking pin service tool

In the interest of safety we have designed and constructed a special service tool, a locking pin that when inserted through the outer cases, locks the drum from being able to rotate when carrying out service work.

These tools can be purchased from your nearest distributor.

We recommend that this tool be used to prevent damage to the reel or to the service person.

By simply rotating the drum, pulling the hose slowly and looking into the service pin hole shown below you will see the line up holes, insert the pin right through the reel so that it protrudes out the opposite side.

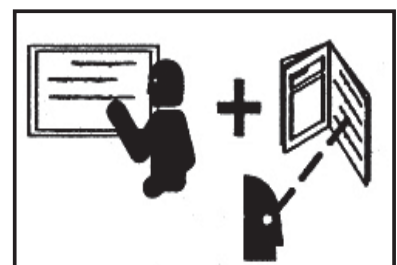
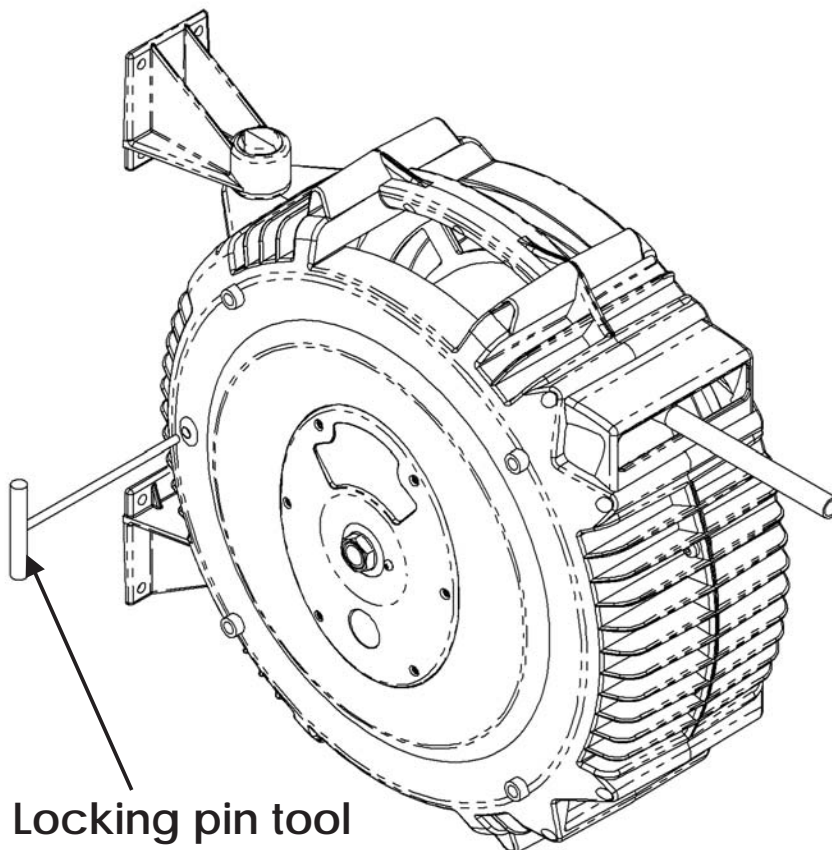

## Checking for leaks

Like all moving and rotating components there is a need to make regular maintenance checks. Some of these checks are very simple and only require a visual inspection. Other checks require service work to be carried out on items such as seals and O-rings. For O-ring and seal servicing, refer to "servicing O-rings and seals" on the following page of this manual.

From time to time we recommend that the user check for leaks. Liquid leaks are easily found, however, gas leaks require some form of leak test. A soapy water test is the most simple. Soapy water brushed around each joint will soon indicate a leak when bubbles appear.

Oxygen and Fuel gas reels should be checked regularly to prevent the possibility of fire due to leaking of flammable gases. The soapy water test also applies here, however, a quick test to determine a leak or not is to pressurise the lines, ensure the blow torch or appliance is turned off. Without touching the regulators, turn the main bottle valve off. If you watch the pressure gauge on the regulator and it begins to drop this indicates there is a leak somewhere between the regulator and the blow torch or appliance. If this occurs, pressurise the system again and apply the soapy water test to find the leak.

## Checking for hose defects

High pressure systems will require a regular test procedure where the system is pressurised to a test pressure and maintained. Most of ReCoila<sup>®</sup>'s PVC hose reels do not require this test and a simple visual inspection will identify potential hose failures. Pull all of the hose from the reel and lock it in the final position, sliding the hose through your hands look for cuts, bruises, cracks, blistering or hardening of the hose's skin. Should you find any of these conditions, point these out to your workshop foreman or manager so that the appropriate action can be taken.

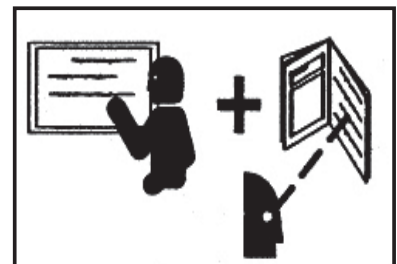

## Servicing or Replacing O-rings, seals, swivels and slip rings

As with normal and scheduled maintenance checks, O-rings and seals will need to be serviced or replaced from time to time. The task of replacing the O-rings and seals is quite simple and should only take a few minutes following the procedure below.

Pull the hose all the way out of the reel, using the service locking tool described in "use of service locking tool", fix the service tool in position. This locks the reel and makes it safe to carry out repairs.

**Note: Never open the tension side plate or adjust tension with the hose fully or partially extended. All of the hose must be fully wound onto the reel.**

Disconnect the inlet supply from the inlet fitting on the reel. Remove the six self-tapping screws in the inlet side plate. Remove the side plate and the swivel.

At the axle end of the swivel, remove the circlip and slide the swivel sleeve off the swivel shaft.

This will expose the O-rings and seals - remove these with an appropriate tool.

**Note: Do not score or scratch the O-ring or seal, sealing surfaces.**

Replace the O-rings and seals and apply an appropriate lubricant.

**Note: Use only ReCoila® original seals and O-rings, failure to do so will void warranty.**

**Note: For Oxygen swivels and connections use only approved lubricants. Refer to your authorities.**

Re-assemble the swivel and re-fit in position, replace the self-tapping screws. Reconnect the inlet supply and check for leaks refer to "checking for leaks" on previous page of this manual.

### Step 1

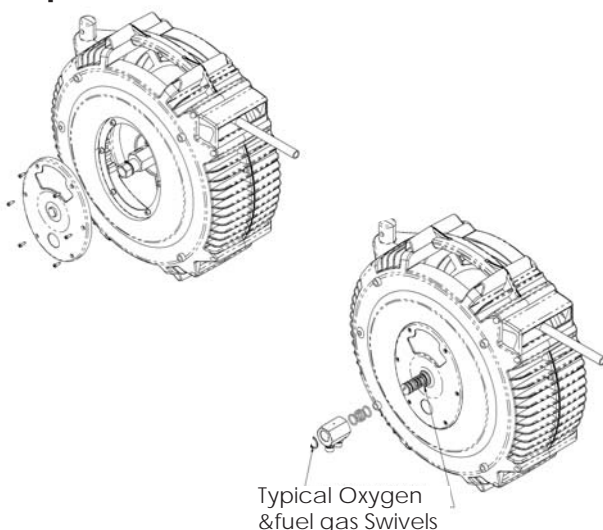

### Step 2

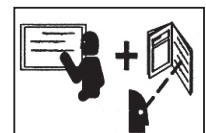
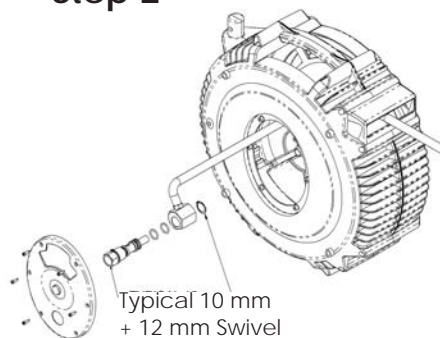

## Adding / removing tension

**Note:** Never add or remove tension when the hose is extended from the reel. The hose must always be fully wound on the hose reel.

### Adding tension

With the hose fully recoiled in the reel, remove the two most inner self-tapping screws locked on the tension ring. With a "C" spanner or the tensioning service tool rotate the cap clockwise one full turn, the tensioning cap is a ratchet system so you will note the clicking as you rotate the cap. Always have the screws vertical when finished, this way you will always know you have a full turn.

**Whenever adding tension only ever add one full turn at a time.**

Before replacing the screws pull the hose out - check to ensure that all of the hose comes out. **If you cannot pull the hose all the way out** and there are remaining coils left on the reel, this indicates that you have **over-tensioned** the spring or that the spring has run out of power and we suggest you contact your service center.

If all is OK, replace the two self-tapping screws to lock the cap in position.

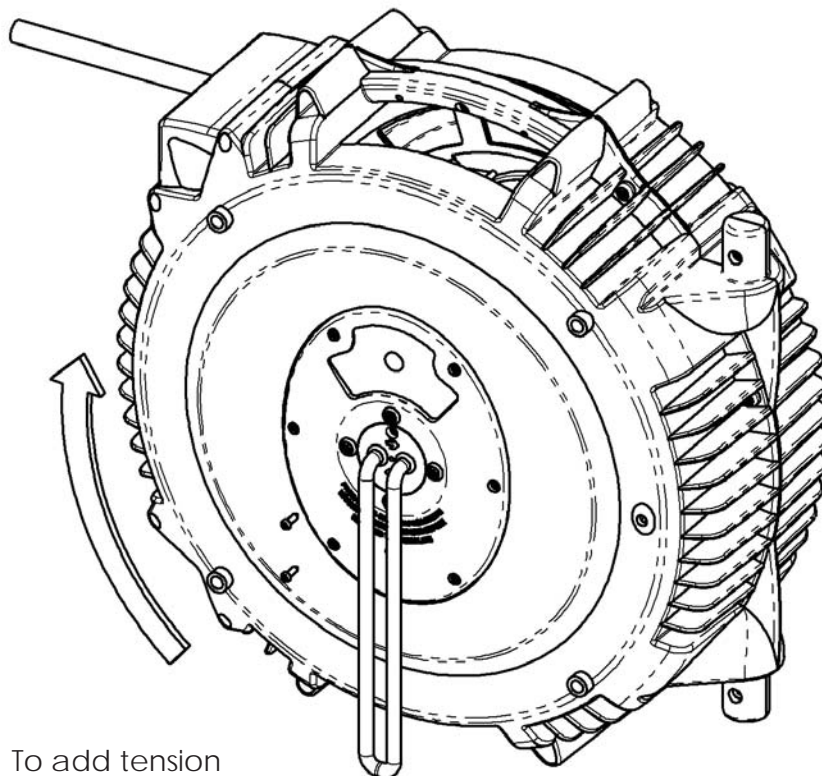

To add tension



**Note: Never add or remove tension when the hose is extended from the reel. The hose must always be fully wound on the hose reel.**

## Removing tension

Removing tension is done for one of two reasons:

1. that you over tensioned your hose reel and cannot pull all the hose out.
2. is that you are replacing the spring drum. There should be no other reason to remove tension from the reel.

Using a "C" spanner or the service tool, hold the centre locking cap and remove the four outer screws.

**Note: There is tension on this cap and it will want to spin anti-clockwise so hold tightly.**

Once the screws are removed, allow the cap to unwind in a controlled manner - when the tension is released the cap will sit stationary. This has now released all the tension. Replace the four self-tapping screws ensuring you locate the correct position between the inner rotating cap and the side plate.

To add tension follow the steps on previous page "Adding tension". If you have removed all the tension and are re-tensioning, add five full turns to start with and then one at a time if necessary.

Repeat the steps as described in "Adding tension".

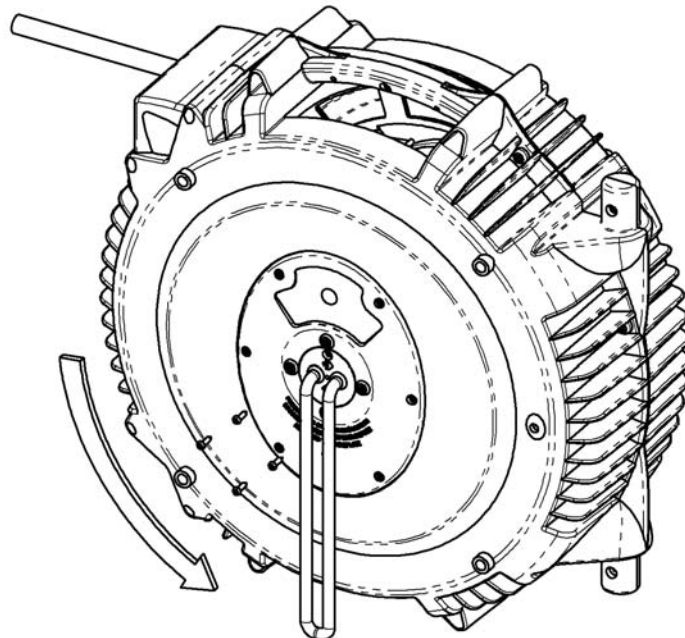

To remove tension



## Repair procedures section

### Replacing the mouth guard

The reel has been designed with a replaceable mouth guard to prevent wear to the case of the reel. The amount of wear on the mouth guard is dependant on the amount of use. To replace this, pull some hose from the reel and lock it in position, remove the four fasteners as shown below, stretch the case open slightly to pop the mouth guard out. Remove the hose bumper and slide the mouth guard off and fit the new one in reverse order.

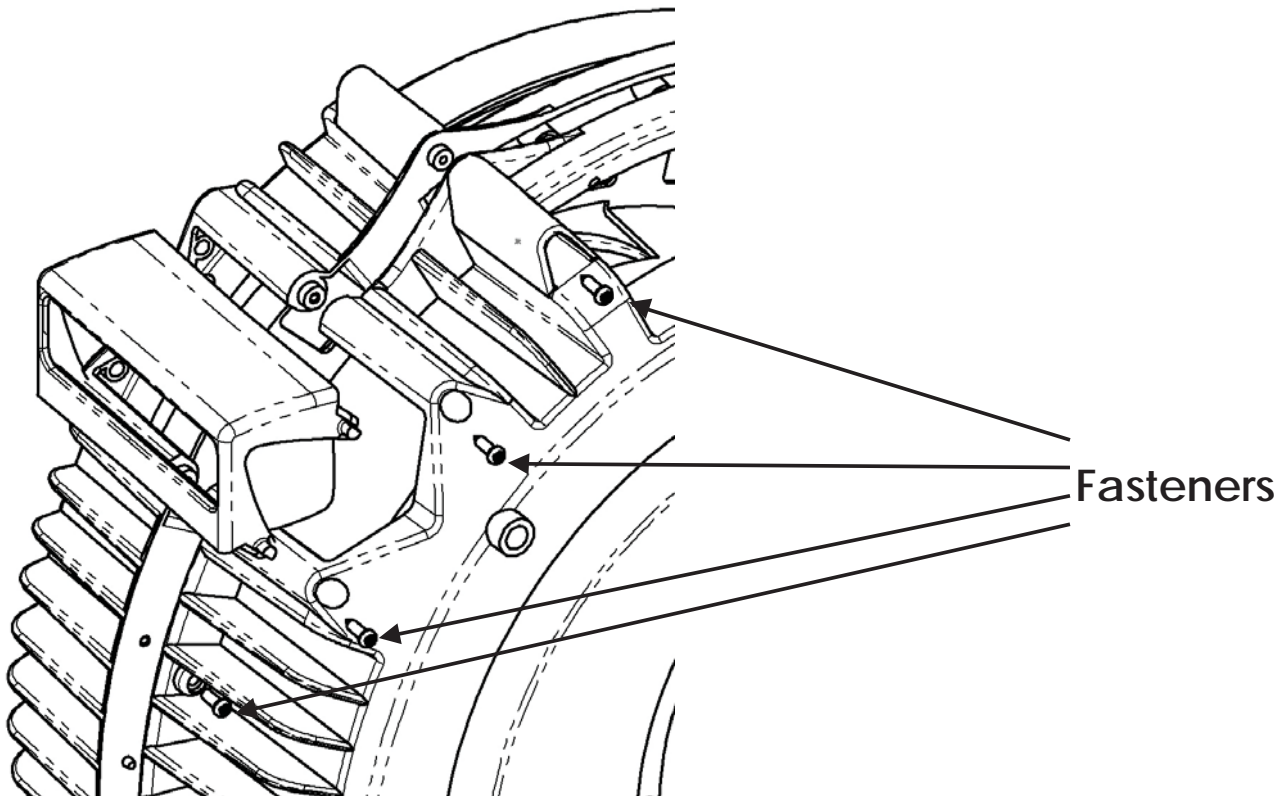

### Replacing swivels, slip-rings and O-rings/seals

**Note: Repairs to electrical cable reels should be carried out by authorised electricians only.**

The task of replacing the swivel is the same as replacing the O-rings and seals.

Follow the procedure on the next page.

Pull the hose all the way out of the reel, using the service locking tool described on page 16 of this manual "inserting the locking pin service tool" fix the service tool in position. This locks the reel and makes it safe to carry out repairs.

**Note: Never open the tension side plate or adjust tension with the hose fully or partially extended. All of the hose or cable must be fully retracted onto the reel (i.e. fully wound on the drum of the reel).**

Disconnect the inlet supply from the inlet fitting on the reel or disconnect the supply cable for the electrical reels.

Remove the six self-tapping screws in the inlet side plate.

Remove the side plate and the swivel. You will note that the hose is connected to the inner drum with a cable tie, cut the cable tie being careful not to cut the hose. Once this is done it will allow you to pull the hose through the side plate cavity. Pull the hose out far enough to get free access. Disconnect the hose from swivel "for the electrical reels loosen the screws holding the main cable". Re-connect the new hose assembly to the swivel, replace the swivel and refit the cable tie to hold the hose to the drum and refit the swivel and side plate. Reconnect the inlet supply and check for leaks. Electrical reels should be tested for earth leakage, continuity and correct wiring connection.

Remove the service tool while holding the main cable or hose and allow the cable or hose to retract.

**Note: Use only ReCoila<sup>®</sup> original components failure to do so will void warranty.**

**Note: For Oxygen swivels and connections use only approved lubricants. Refer to your local authorities.**

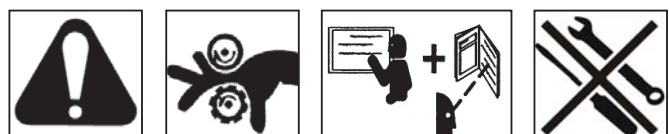
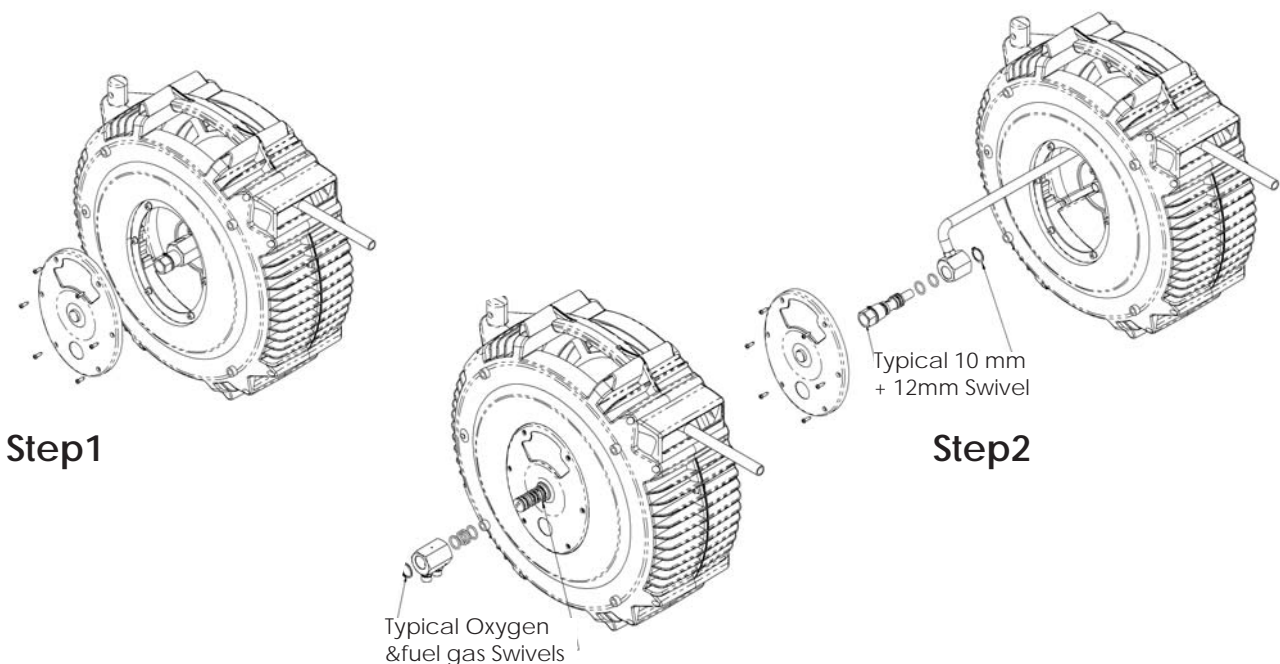

## Replacing the hoses or cables

**Note: Repairs to electrical cable reels should be carried out by authorised electricians only.**

Follow the same procedure as “replacing the swivel or slip-ring” once you have disconnected the hose from the swivel or removed the slip-ring pull the hose or cable from the reel via the main opening.

**Note: always check the length and diameter of your replacement hose or cable to ensure it is the same length and diameter as the hose or cable originally supplied on the reel. Each model of reel is designed to retract a certain length and diameter of hose or cable only. Longer lengths or larger diameters will damage the reel and void warranty.**

Replace the hose or cable by feeding it through the mouth of the reel and then through the opening in the drum and reconnect to the swivel or slip-ring.

Refit the cable tie to hold the hose to the drum and refit the swivel and side plate.

Reconnect the inlet supply and check for leaks. Electrical reels should be tested for earth leakage, continuity and correct wiring connection.

Remove the service tool while holding the main cable or hose and allow the cable or hose to retract.

**Note: Use only ReCoila® original components failure to do so will void warranty.**

**Note: For Oxygen swivels and connections use only approved lubricants. Refer to your local authorities.**



## Replacing the tension locking system

**Note: Never open the tension side plate or adjust tension with the hose fully or partially extended. All of the hose or cable must be fully retracted onto the reel (i.e. fully wound on the drum of the reel)**

The first step is to remove tension from the reel. Following the "removing tension" procedure on page 20 of this manual.

Remove the six self-tapping screws holding the tension side plate plus the very centre screw located in the centre of the tension wheel.

Once you have removed the side plate check to see if there is any damage to the locking teeth/ratchet teeth located on the inner drum.

If the locking teeth/ratchet teeth are damaged or broken you will need to replace the inner drum spring canister. Refer "replacing broken spring" on page 26 of this manual.

If these are all OK and without damage, refit the new side plate assembly and follow the procedure for re-tensioning the reel in the previous section.

To add tension follow the steps in the "Adding tension" section on page 19.

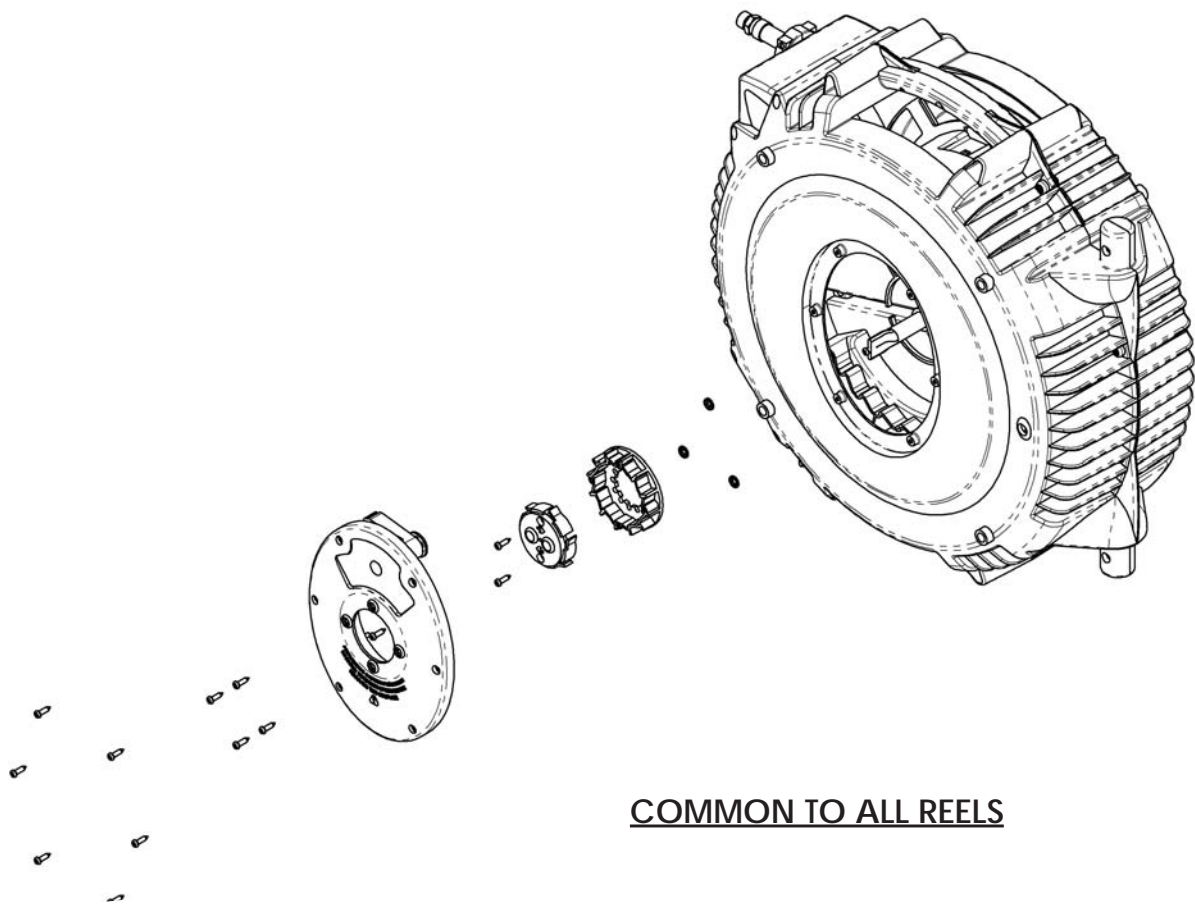

**COMMON TO ALL REELS**



## Replacing the outer case

To replace the outer cases you must first follow the procedure for “replacing the locking system” on previous page. Once you have removed the tension and removed the tension side plate, remove the inlet side plate as you would if you were going to replace the swivel. However do not disconnect the swivel from the hose.

Remove the screws around the outer case and split the two halves. Refit the drum into the new case halves and replace the screws.

Refit the inlet side plate. Refit the tension side plate and follow the procedure for “replacing the tension locking system”.

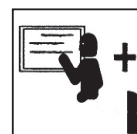
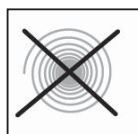
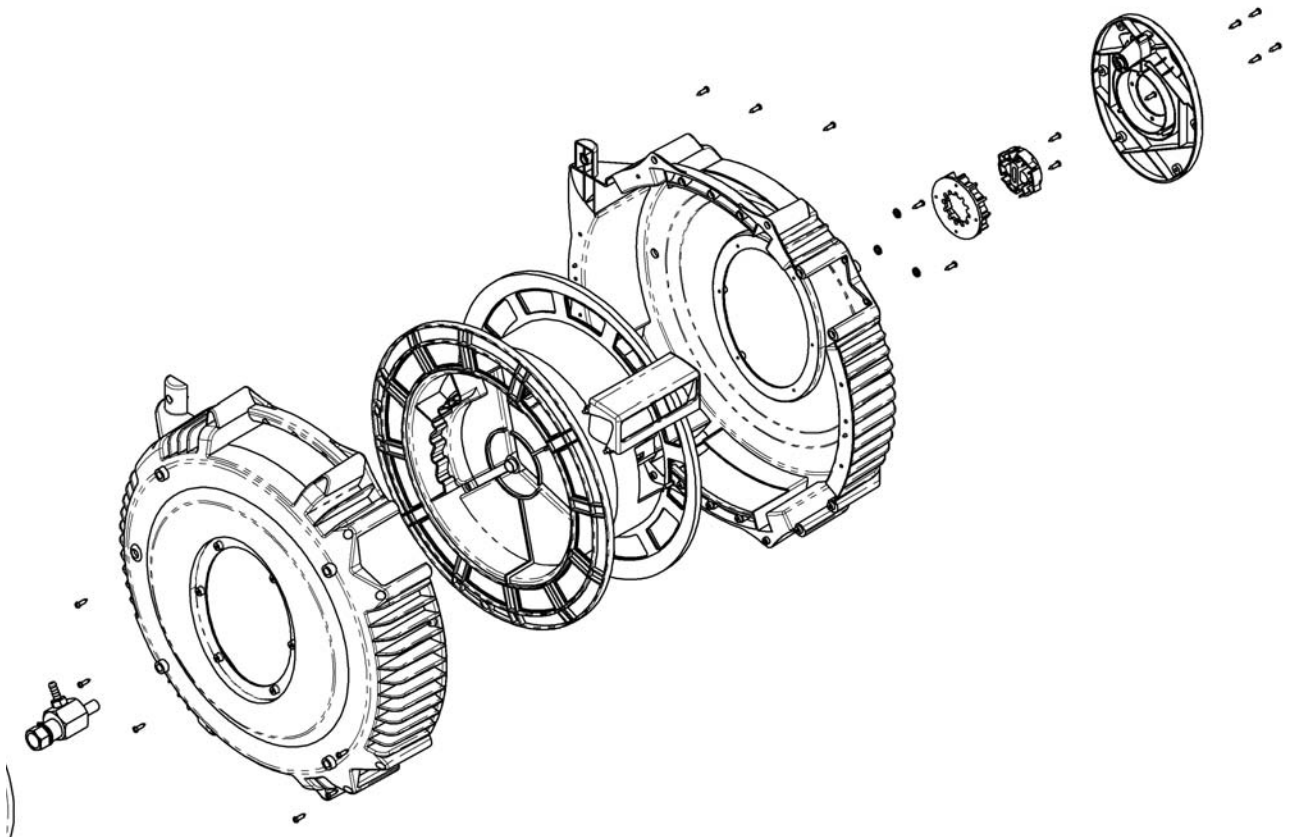

## Replacing a broken spring

**Note: Never open the spring drum assembly as it contains a coiled spring and could cause serious injury.**

Due to safety factors we do not sell just the spring, instead we sell a complete spring assembly called the spring drum assembly. To replace the spring drum assembly follow the procedure for "replacing the outer cases" on previous page. Once you have the drum out of the reel, remove the hose and refit to the new drum. Rebuild the reel in the same manner as described in "replacing the outer cases" section.

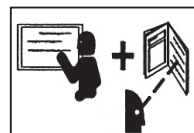
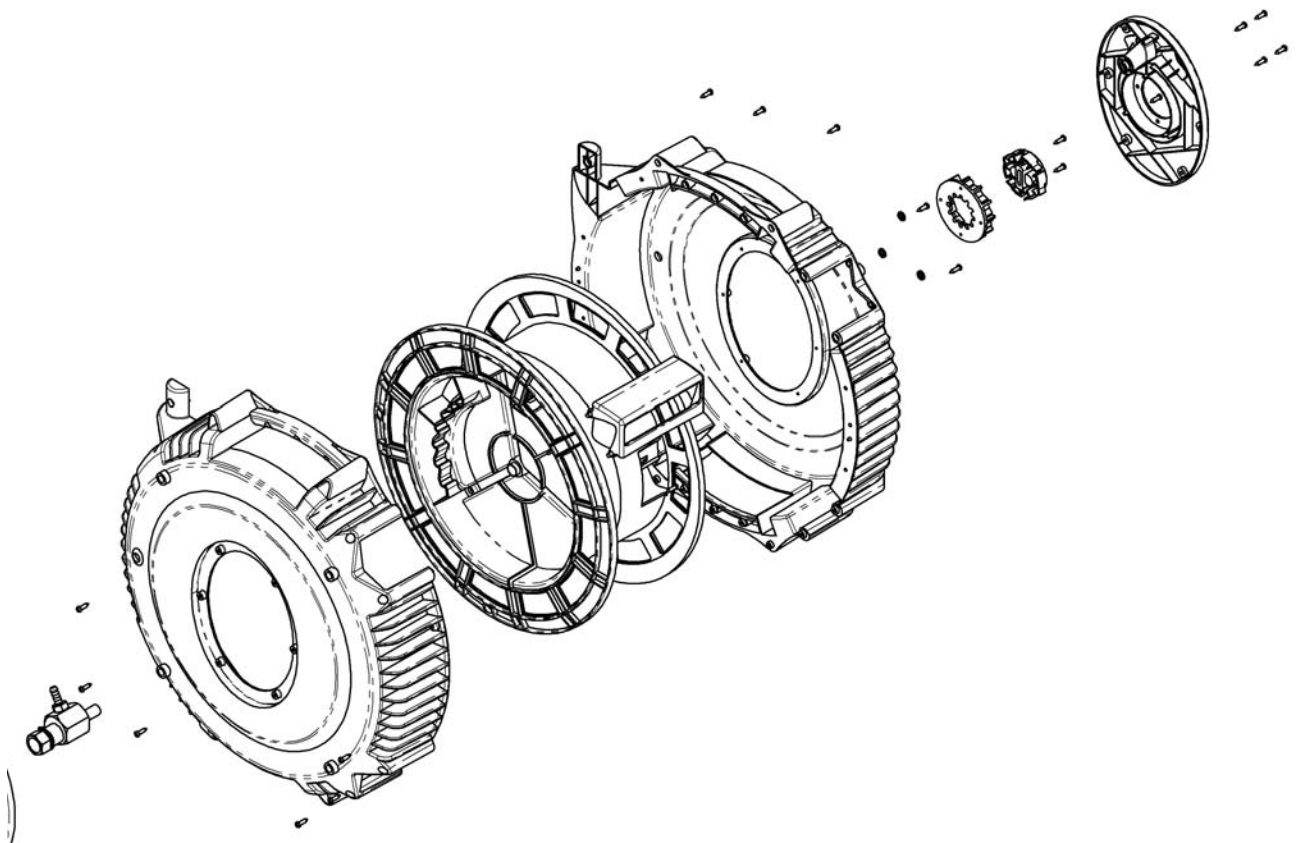

# Parts break down

## Typical main assembly

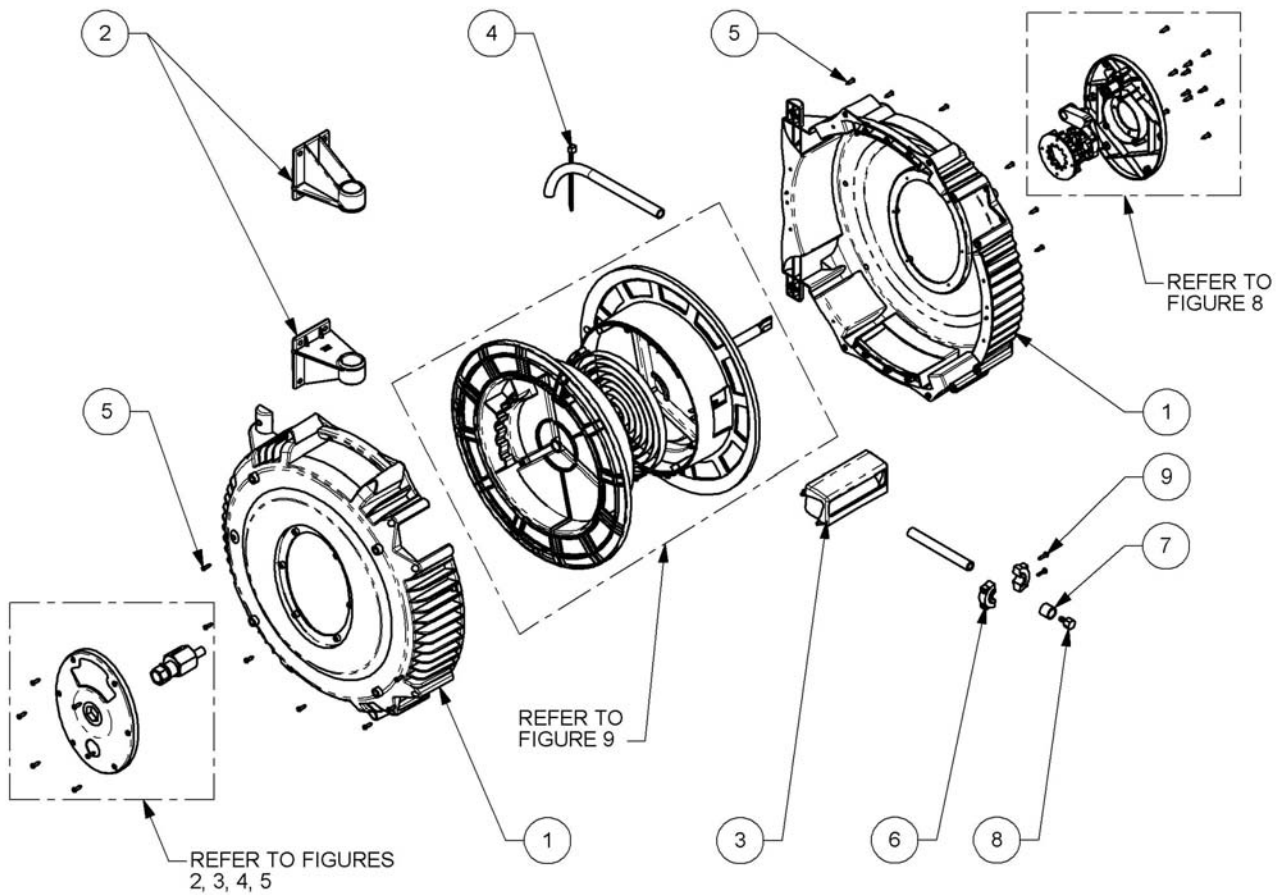

DRAWING FIGURE 1

Note: Not all items are sold as individual parts - complex assemblies and spring assemblies are sold in sub-assembly kit form.

Note: Use only ReCoila<sup>®</sup> original components failure to do so will void warranty.

## Parts break down

Typical compressed air and liquid swivel assemblies

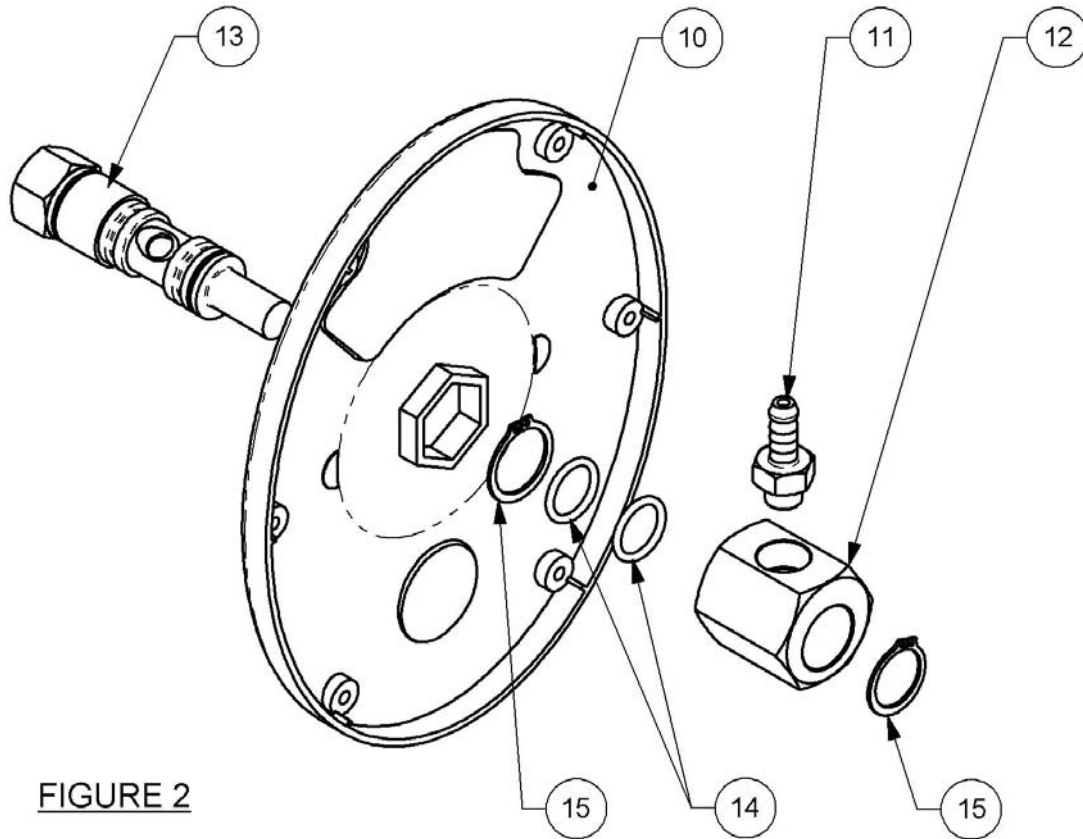

FIGURE 2

Note: Use only ReCoila<sup>®</sup> original components failure to do so will void warranty.



## Parts break down

### Typical Oxygen and Fuel gas swivels

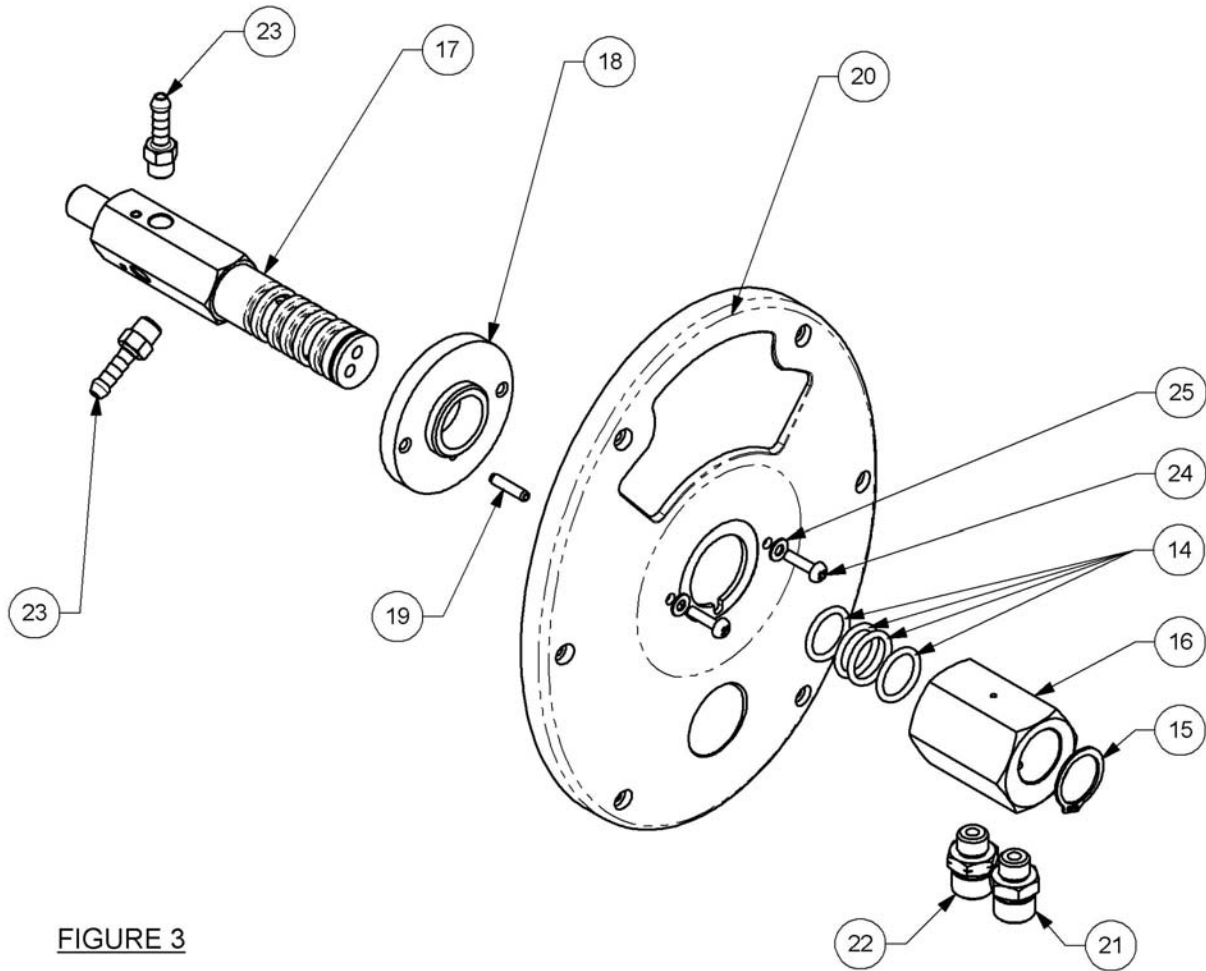

FIGURE 3

Note: This item is sold as an assembly. O-ring service kits are sold separately please quote the model of hose reel you have.

Note: Use only ReCoila<sup>®</sup> original components failure to do so will void warranty.

Note: For Oxygen swivels and connections use only approved lubricants. Refer to your local authorities.



## Parts break down

### Typical high pressure grease swivel

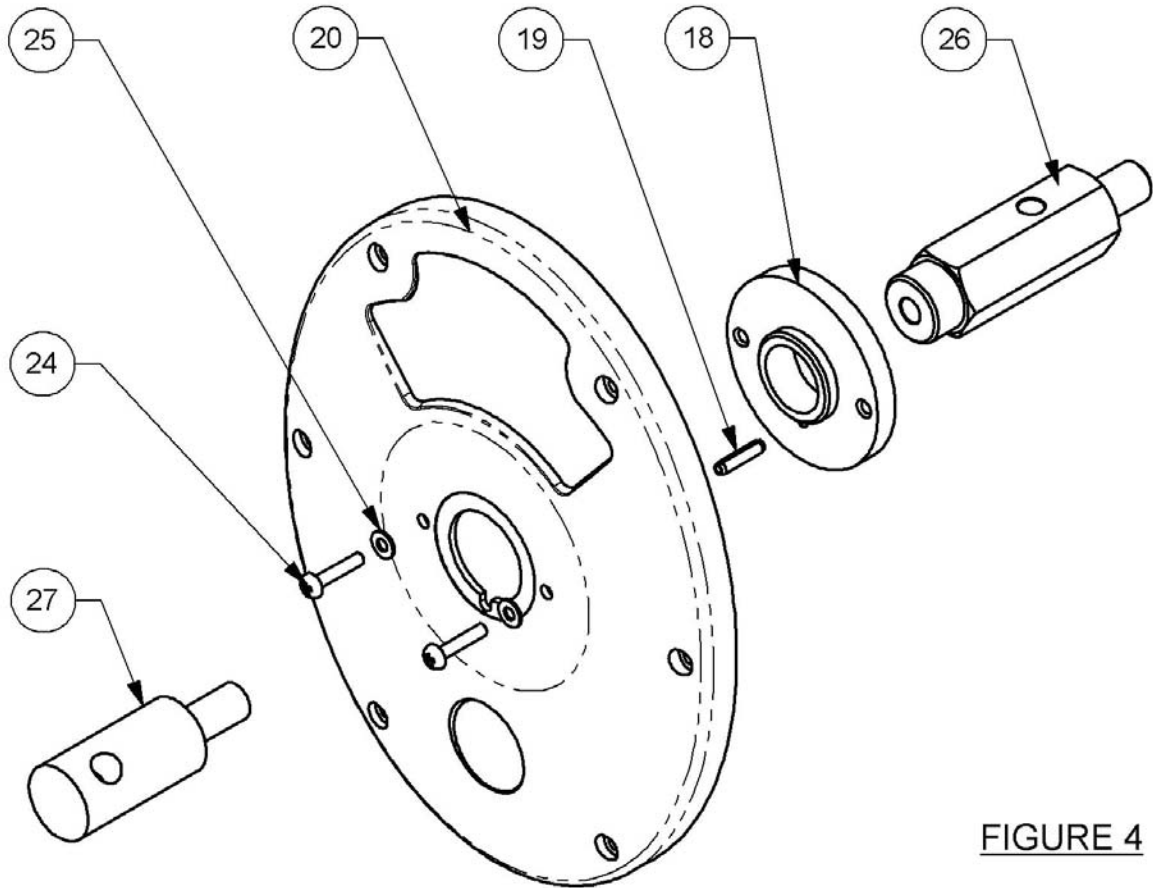

**FIGURE 4**

Note: This item is sold as an assembly. O-ring service kits are sold separately please quote the model of hose reel you have.

Note: Use only ReCoila<sup>®</sup> original components failure to do so will void warranty.



## Parts break down

### Typical electrical slip ring assembly

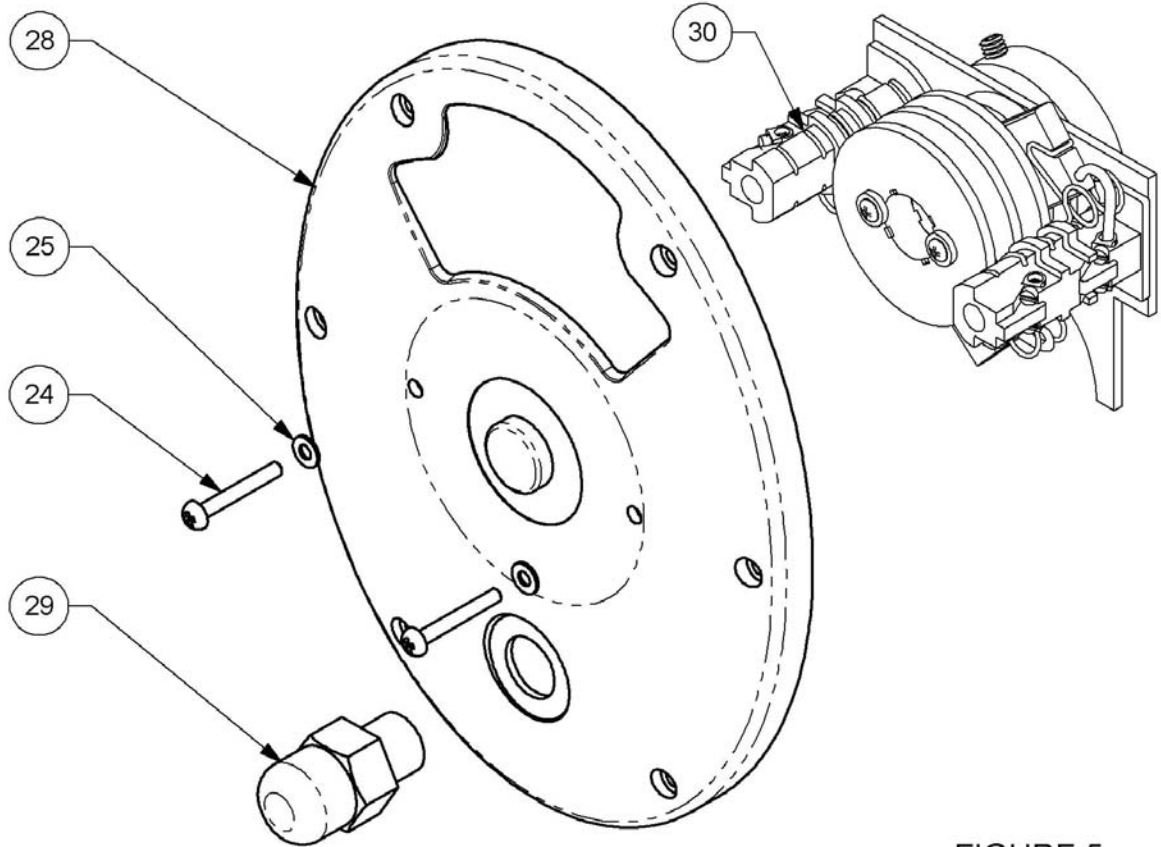

FIGURE 5

Note: This item is sold as an assembly. For slip rings please state what model reel you have.

Always disconnect the electrical supply before carrying out any service or maintenance work.

It is recommended that you use a certified electrical contractor to make any repairs.

Note: Use only ReCoila<sup>®</sup> original components failure to do so will void warranty.



## Parts break down

### Typical tension side plate assembly

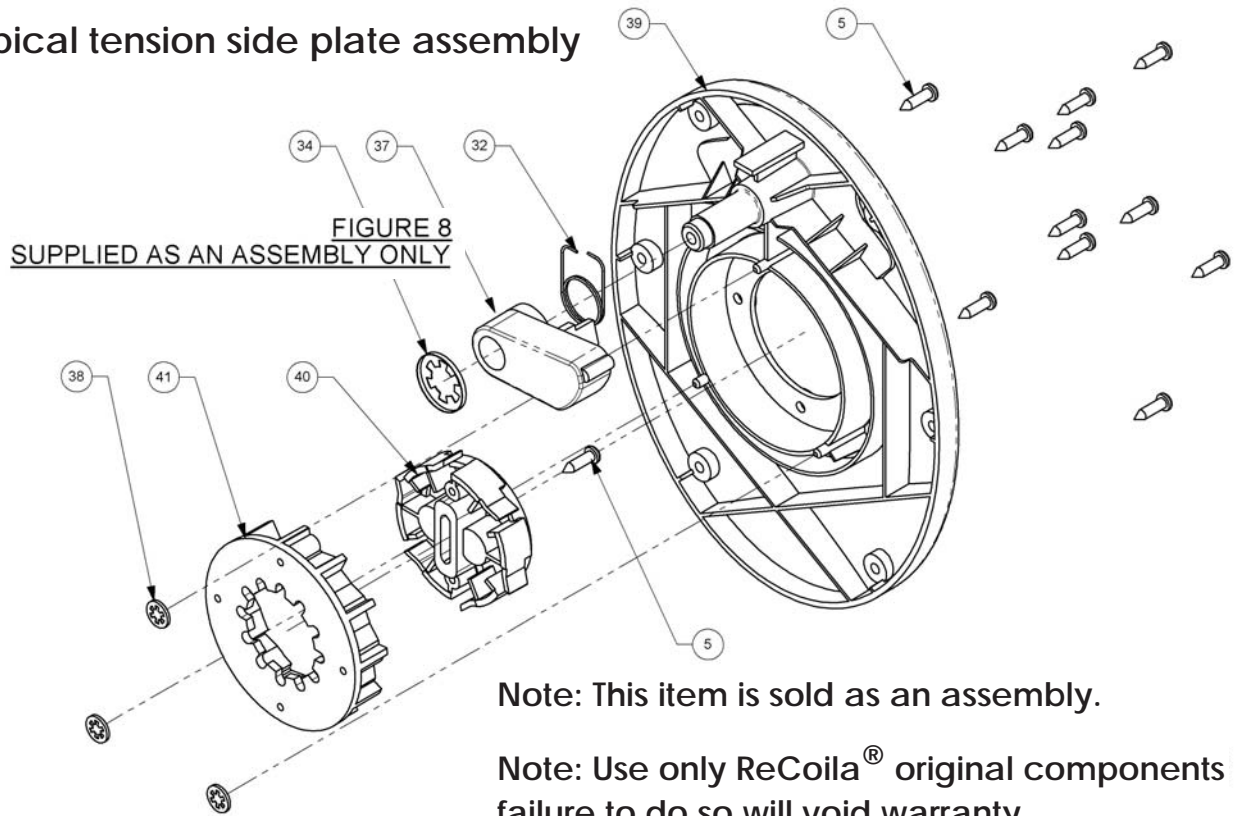

## Parts break down

### Typical drum and spring assembly

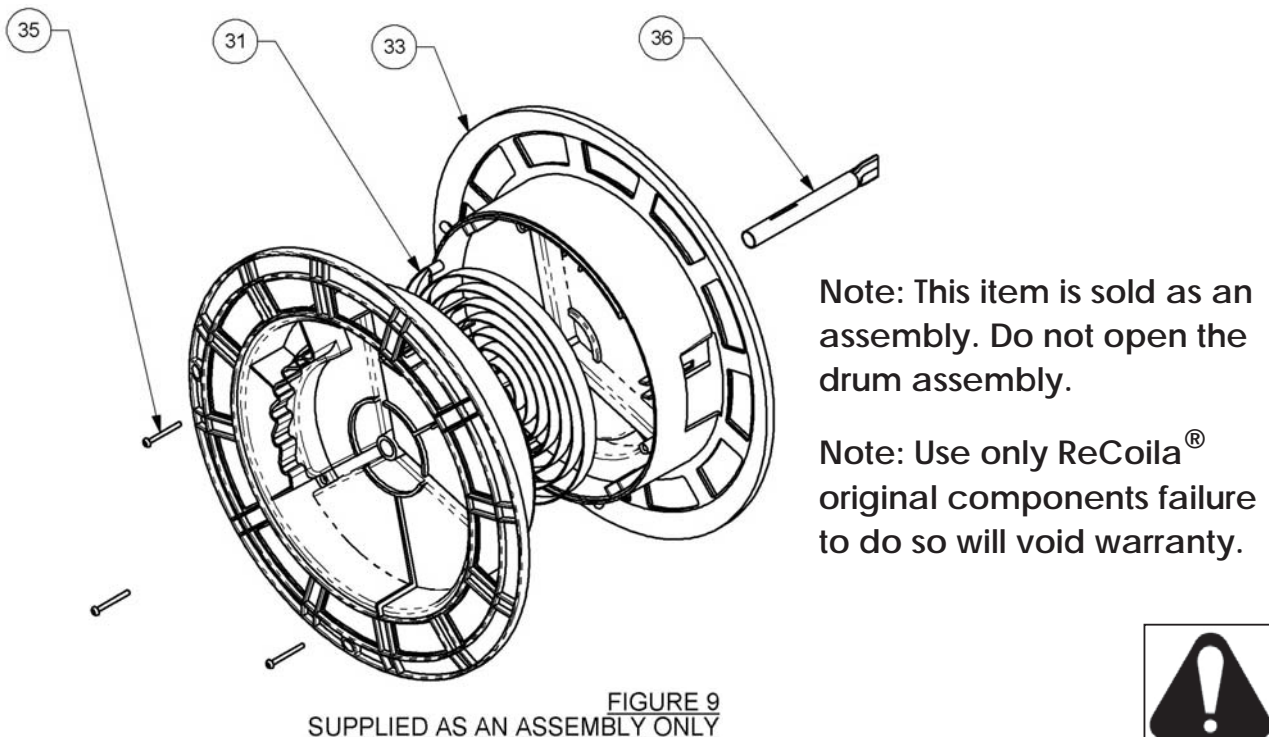

## Numerical part numbers

| Item n/o | Ordering code | Description                           |
|----------|---------------|---------------------------------------|
| 1        | SG0405-B      | OVAL OUTER CASE BLUE                  |
| 1        | SG0405-BLK    | OVAL OUTER CASE BLACK                 |
| 1        | SG0405-G      | OVAL OUTER CASE GREEN                 |
| 1        | SG0405-R      | OVAL OUTER CASE RED                   |
| 1        | SG0405-Y      | OVAL OUTER CASE YELLOW                |
| 2        | SG0023A       | WALL ANGLE BRACKETS ALL REELS         |
| 3        | SG0408        | MOUTH GUARD NYLON                     |
| 4        | SG0112        | CABLE TIE 194MM                       |
| 5        | SG0260        | 8# X 3/4" PAN PR HI-LO Z/GOLD B POINT |
| 6        | SG0017        | 10-MM HOSE BUMPER                     |
| 6        | SG0040        | 12-MM HOSE BUMPER                     |
| 6        | SG0041        | 8-MM HOSE BUMPER                      |
| 6        | SG0042        | 6-MM HOSE BUMPER                      |
| 6        | SG0060        | TWIN 11-MM HOSE BUMPER                |
| 7        | SG0099        | BRASS FERRULE 14-27 I.D.              |
| 7        | SG0221        | BRASS FERRULE BFM687                  |
| 7        | SG0222        | BRASS FERRULE BFM718                  |
| 7        | SG0226        | BRASS FERRULE BFM78119.84 X 15.88     |
| 7        | SG0226B       | BFM 718B FERRULES 19.84 X 12.70       |
| 7        | SG0250        | BRASS FERRULE BFM478                  |
| 8        | SG0020        | HOSE BARB 3/8 X 3/8 BSPT              |
| 8        | SG0048        | HOSE BARB 1/2" X 3/8 BSPM             |
| 8        | SG0063        | HOSE BARB OXY / FUEL GAS 5MM          |
| 8        | SG0064        | OXY NUT 5/8 UNF R/H FEMALE            |
| 8        | SG0065        | ACCET NUT 5/8 UNF L/H FEMALE          |
| 8        | SG0129        | HOSE BARB 3/8 X 1/4 NTP               |
| 8        | SG0132        | HOSE BARB 1/2X1/2 NTP                 |
| 8        | SG0146        | OXY AND ACET NUTS 3/8 BSP             |
| 8        | SG0228        | HOSE BARB 1/2" BARB 3/8" NPT          |
| 8        | SG0236        | HOSE BARB 3/8" X 3/8" NPT             |
| 8        | SG0244        | HOSE BARB 1/4" BSPT X 3/8"            |
| 8        | SG0248        | HOSE BARB 1/4" X 3/8 BSPM             |
| 9        | SG0237        | BOLT 1/4" X 1 1/4" PAN XRMTSZT        |
| 9        | SG0238        | NUT 1/4" HNZP                         |
| 10       | SG0402-B      | OVAL INLET SIDE PLATE LARGE HEX BLUE  |
| 10       | SG0402-BLK    | OVAL INLET SIDE PLATE LARGE HEX BLACK |
| 10       | SG0402-G      | OVAL INLET SIDE PLATE LARGE HEX GREEN |

## Numerical part numbers continued

| Item n/o | Ordering Code | Description                            |
|----------|---------------|--|
| 10       | SG0402-R      | OVAL INLET SIDE PLATE LARGE HEX RED    |
| 10       | SG0402-Y      | OVAL INLET SIDE PLATE LARGE HEX YELLOW |
| 11       | SG0020-S      | SWIVEL HOSE BARB SHORT 3/8 X 3/8" BSP  |
| 11       | SG0048-S      | SWIVEL HOSE BARB SHORT 1/2 X 3/8" BSP  |
| 11       | SG0228-S      | SWIVEL HOSE BARB SHORT 1/2 X 3/8" NPT  |
| 11       | SG0236-S      | SWIVEL HOSE BARB SHORT 3/8 X 3/8 NPT   |
| 12       | SG0504-B      | GEN 3 25-MM HEX SWIVEL BODY 3/8" BSPP  |
| 12       | SG0505-B      | GEN 3 25-MM HEX SWIVEL BODY 1/2" BSPP  |
| 12       | SG0506-B      | GEN 3 25-MM HEX SWIVEL BODY 3/8" NPTS  |
| 12       | SG0507-B      | GEN 3 25-MM HEX SWIVEL BODY 1\2" NPTS  |
| 12       | SG0508-B      | GEN 3 22-MM HEX SWIVEL BODY 3/8" BSPP  |
| 12       | SG0509-B      | GEN 3 22-MM HEX SWIVEL BODY 3/8" NPTS  |
| 13       | SG0504-S      | GEN 3 25-MM HEX SWIVEL SHAFT 3/8" BSPP |
| 13       | SG0505-S      | GEN 3 25-MM HEX SWIVEL SHAFT 1/2" BSPP |
| 13       | SG0506-S      | GEN 3 25-MM HEX SWIVEL SHAFT 3/8" NPTS |
| 13       | SG0507-S      | GEN 3 25-MM HEX SWIVEL SHAFT 1/2" NPTS |
| 13       | SG0508-S      | GEN 3 22-MM HEX SWIVEL SHAFT 3/8" BSPP |
| 14       | SG0071        | O-RING BS115 NBR                       |
| 14       | SG0203        | O-RING BS115 VITON                     |
| 14       | SG0204        | O-RING BS115 EPDM                      |
| 15       | SG0070        | 22MM EXTERNAL CIRCLIP                  |
| 16       | SG0501        | GEN 3 OXY & FUEL GAS SLEEVE            |
| 17       | SG0500        | GEN 3 OXY AND FUEL SHAFT               |
| 18       | SG0502        | GEN 3 HP / OXY & FUEL GAS BEZEL        |
| 19       | SG0137        | ROLL PIN - 6MM OD X 36MM               |
| 20       | SG0403-B      | OVAL INLET S/PLATE HP OXY FUEL BLUE    |
| 20       | SG0403-BLK    | OVAL INLET S/PLATE HP OXY FUEL BLACK   |
| 20       | SG0403-G      | OVAL INLET S/PLATE HP OXY FUEL GREEN   |
| 20       | SG0403-R      | OVAL INLET S/ PLATE HP OXY FUEL RED    |
| 20       | SG0403-Y      | OVAL INLET S/PLATE HP OXY FUEL YELLOW  |
| 21       | SG0076        | OXY EXT NIPPLE SET 5/8 UNF             |
| 21       | SG0077        | CIRCLIP 24-MM EXTERNAL NEW OXY SHAFT   |
| 21       | SG0078A       | ACET EXT NIPPLE 3/8" BSP               |
| 21       | SG0091        | OXY EXT NIPPLES 9/16-18 UNF            |
| 21       | SG0094        | OXY EXT NIPPLES M16 JIS                |
| 22       | SG0076A       | ACET EXT ADAPTOR 5/8 UNF               |
| 22       | SG0078        | OXY EXT NIPPLES 3/8 BSP                |

## Numerical part numbers continued

| Item n/o | Ordering Code | Description                           |
|----------|---------------|---------------------------------------|
| 22       | SG0091A       | ACET EXT NIPPLE 9/16-18               |
| 22       | SG0094A       | ACET EXT NIPPLES M16 JIS              |
| 23       | SG0138        | HOSE BARB 1/4" X 1/8 BSPM             |
| 23       | SG0215        | HOSE BARB 3/16" X 1/8 BSP             |
| 24       | SG0229        | M4 X 8MM PHILLIPS HEAD BOLT           |
| 25       | SG0239        | WASHER ZP 5/32 X 7/16 X 20G #02136406 |
| 26       | SG0503        | GEN 3 HP SWIVEL SHAFT 5000 PSI        |
| 27       | SG0253        | HP GREASE SWIVEL PS490102-4-4         |
| 28       | SG0404-B      | OVAL ELECTRICAL S/PLATE BLUE          |
| 28       | SG0404-BLK    | OVAL ELECTRICAL S/PLATE BLACK         |
| 28       | SG0404-G      | OVAL ELECTRICAL S/PLATE GREEN         |
| 28       | SG0404-R      | OVAL ELECTRICAL S/PLATE RED           |
| 28       | SG0404-Y      | OVAL ELECTRICAL S/PLATE YELLOW        |
| 29       | SG0111        | CABLE GLAND M20 X 1.5                 |
| 30       | SG0122        | 3 PHASE, 4 X RING, SLIP RING          |
| 30       | SG0124        | SINGLE PHASE SLIP RING 3 X RING       |
| 31       | SG0015        | MAIN SPRING PER                       |
| 32       | SG0016        | TORSION SPRING LOCKING PAWL           |
| 33       | SG0018        | INNER DRUM ALL REELERS (PAIR)         |
| 34       | SG0019        | 12-MM P/ON FASTENER 73020012          |
| 35       | SG0025        | M5 X 60MM PAN XR ZINC HIGH LOW THREAD |
| 36       | SG0062        | DRUM AXLE                             |
| 37       | SG0232        | ReCoila PAWL                          |
| 38       | SG0318        | PUSH ON FASTENER RGA 156RMIP M4       |
| 39       | SG0401-B      | OVAL TENSION SIDE PLATE BLUE          |
| 39       | SG0401-BLK    | OVAL TENSION SIDE PLATE BLACK         |
| 39       | SG0401-G      | OVAL TENSION SIDE PLATE GREEN         |
| 39       | SG0401-R      | OVAL TENSION SIDE PLATE RED           |
| 39       | SG0401-Y      | OVAL TENSION SIDE PLATE YELLOW        |
| 40       | SG0406        | LOCKING TENSION CAP                   |
| 41       | SG0407        | RATCHET LOCKING RING                  |



# Contact Us

## Head Office Australia

Postal address:

PO BOX 6463 BC  
Blacktown NSW 2148  
Australia

Phone

(61) 2 9621 8988

Email

[sales@recoila.com.au](mailto:sales@recoila.com.au)

Street address:

Unit 1/10 Melissa Place  
Kings Park NSW 2148  
Australia

Fax

(61) 2 9621 7688

Web

[www.recoila.com.au](http://www.recoila.com.au)

## New Zealand Warehouse & Distribution

Postal address:

PO BOX 101582  
North Shore Mail Centre  
North Shore City 0745  
New Zealand

Phone

(64) 9 4410177

Email

[sales@recoila.co.nz](mailto:sales@recoila.co.nz)

Street address:

Unit 1/A 93 Ellice Rd  
Glenfield  
North Shore City 0629  
New Zealand

Fax

(64) 9 4410178

Web

[www.recoila.co.nz](http://www.recoila.co.nz)