



ReCoila

HOSE AND CORD REELS

Operation and Service Manual for ReCoila® Spring Rewind hose, cord & cable Reels



ReCoila® GEN IV

Engineered Confidence

www.recoila.com.au
www.recoila.co.nz

Revision date: January 2012

For Models after the 1st October 2007



SAFETY FIRST!

ReCoila highly recommends that any operator familiarise themselves with the following points and other information contained in this manual

before operating the reel.

Remember - safety first, become familiar with the operation and function of your new hose or cable reel to avoid injury and damage to the reel.

THE DO'S AND DON'TS OF REEL OPERATION:

DON'T let the hose, cord or cable fly back into the reel uncontrolled.

DO walk back to the reel with the hose or cable end, place it safely down and with one hand, release the locking system allowing the hose / cable to rewind back into the reel in a controlled fashion.

DON'T let the hose / cable end, gun, socket or nozzle impact into the reel.

DO Control the wind allowing the gun, nozzle or socket to rest up against the opening of the reel then pull it out and allow it to lock with a short section of hose or cable hanging from the reel. This allows the locking system to hold the hose, not the end fittings.

DON'T pull the hose from the reel by the gun, socket or nozzle end.

DO hold the hose or cable when pulling or dragging the hose or cable around.

DON'T walk away from the reel pulling the hose or cable by the gun, socket or nozzle.

DO stand at the reel and pull out the required length of hose or cable and lock in position, letting the hose or cable fall to the ground. Then, holding the hose or cable near the end fitting, walk to the work area.

DON'T use the hose or cable reel if you notice and cracked, fractured, split, damaged, frayed or swelling hose or cable.

DO have your plant supervisor made aware immediately and isolate the reel.

Overview

The following operation, service and repair manual has been designed to give the operator / user a full understanding of the operational aspects of the hose and cable reels as well as being a supplement to our factory service and maintenance training course.

The basic principle of each reel is the same and the repair or service is carried out in the same manner from one model to the next, however certain models require higher levels of technical knowledge.

These reels are listed separately as is their respective parts breakdown.

Table of Contents

About us	6
Quality and Certification	
CE Declaration of Conformity	7
Supplier Declaration of Conformity	8
Listing of explanation symbols	9
ReCoila [®] 's quality statement	10
Terms and conditions of warranty	11
Installation instructions	
Connection of the inlet hose	12
Mounting the reel	13
How to use the reel	14
Adding and removing spring tension	15
Spare parts breakdowns	
General parts breakdown	17
Electrical parts breakdown	18
Numerical part number listing	19

About Us

ReCoila® is a wholly Australian owned company with a manufacturing facility in the industrial precinct of Kings Park situated in the western region of Sydney.

ReCoila® has been manufacturing quality hose reels for some 30 years servicing both domestic and international markets.

Our range of reels includes composite spring rewind hose and cable reels, fabricated steel reels in powder coated finish, stainless steel and aluminium with hand crank, and motorised versions.

ReCoila® as a manufacturer offers an extensive range of Australian made hose cord and cable reels, this range is supplemented with selected products from renowned quality manufacturers in the USA and Europe to bring you the most comprehensive range of hose, cord and cables reels.

Our stringent in house testing ensures all products meet the quality that you expect from ReCoila® whether it be an Australian made reel or manufactured elsewhere and distributed by us. Our aim has always been to design and manufacture the best reels available at a cost effective price.

We continue to lead the way in design, innovative ideas, functionality and reliability of our products and utilise state of the art manufacturing methods setting the standards for others to follow.

ReCoila® is committed to continued quality and engineering excellence balanced with price competitiveness to supply users with the best reels available.

Hence we proudly say

“Engineered Confidence”

CE Declaration of Conformity

We,

Strata Group (Aust) Pty Ltd
Unit 1/10 Melissa Place
Kings Park NSW 2148
Australia
Phone: (61) 2 9621 8988
Fax: (61) 2 9621 7688

Declare under our sole responsibility that the product ReCoila[®] Spring rewind hose cord and cable reels, to which this declaration relates, is in conformity with the following documents.

Strata design specifications and acceptance criteria following the provision of 98/37EC (Machinery Directive).

The technical construction file is maintained at the following addresses:

1.

Strata Group (Aust) Pty Ltd
Unit 1/10 Melissa Place
Kings Park
NSW 2148
Australia
Phone: (61) 2 9621 8988
Fax: (61) 2 9621 7688

2.

Reelcare
Unit L Tyson Courtyard
Weldon South Industrial Estate
Corby Northamptonshire NN18 8AZ
United Kingdom
Phone: (44) 1536 407001
Fax: (44) 1536 261491

Supplier Declaration of Conformity (SDoC)

In accordance with ISO/IEC 17050-1:2004

SDoC identification Number¹ -			
Issuer details			
Name² (of New Zealand manufacturer or importer)		Contact Address	
RECOILA NZ PTY LTD		UNIT 1A 93 ELLICE ROAD GLENFIELD, NORTH SHORE CITY, 0629 NEW ZEALAND	
New Zealand Company Number (if applicable)			
Telephone		Fax	
9441 0177		9441 0178	
Email address			
sales@recoila.co.nz			
Medium Risk Article – Details ³ (Product name, type, rating, brand, model, batch numbers, and serial numbers, as applicable)			
EL2402010		L24032610	
EL2402015			
EE2401210			
EE2401215			
The Medium Risk Article, listed above, fully complies with the cited standard(s), as listed:-			
Standard number & issue year:- AS/NZS 3105:1993		Standard number & issue year:- AS/NZS3100:1994	
Standard Title:- ELECTRICAL PORTABLE OUTLET DEVICES		Standard Title:-	
Edition / Amendment status:- .1	AS/NZS ZZ modified N	Edition / Amendment status:- .1	AS/NZS ZZ modified N
Or complies with the Conformity Cooperation Agreement - No			
Names and addresses of any testing organisation or body			
Name(s)		Address(es)	
TESTING & CERTIFICATION AUSTRALIA		AUSTRALIA	
DEPARTMENT OF ENERGY		AUSTRALIA	
Reference to relevant test reports/certification, and issue date of the reports/certification, that show how compliance is achieved:-			
Standard(s) or document(s) used, to show how compliance with cited standard is achieved:-		Report/Certification or Document reference N°(s):-	Issue date(s)
AS/NZS3100:1994		N14520	18/9/95
AS/NZS3105:1993			
Reference to any management systems involved:-			
NATA No. 62			
Additional⁴ information			
100% TEST & TAG PROCEDURE			
Declaration			
I hereby declare that the above specified fittings or electrical appliances comply with the requirements of Regulation 83 of the Electricity (Safety) Regulations 2010		Signed for and on behalf of:	
Issuer Identification: (as affixed to the article). <div style="border: 1px solid black; width: 100%; height: 100%;"></div>		RECOILA NZ PTY LTD	
		Names & position, as authorized by the issuer	
		MICHAEL PAWSON	
		Signature	Date 1/12/10

¹ Every declaration of conformity should be uniquely identified.

² The responsible issuer must be unequivocally specified.

³ The "Article" must be unequivocally described so that the declaration of conformity may be related to the article in question. For mass-produced products, it is not necessary to give individual serial numbers. Where variants of an article are to be covered, these must be detailed.

List of precautions symbols



Means Warning! Watch out!
There are possible hazards with this procedure!
Possible hazards are shown by this warning symbol.



Means Warning. Moving parts.
Keep away from moving parts and pinch points.

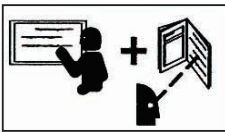

Means consult the service centre or become trained and read the service manual.

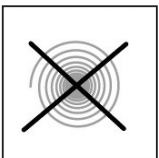

Means Warning. Item under tension, this area contains a tensioned spring.



Means Warning. Do not remove fasteners or attempt to service without contacting a service centre or becoming fully trained on the service and repair of hose reels.



Means Warning.
Never let the hose or cable rewind uncontrolled.

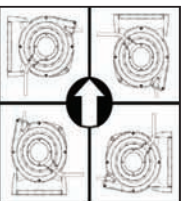

Means all positional locking system.



Means ensure you have full knowledge of the service or repair task being carried out possible hazards.

Note: Please refer to your local authority for rules and regulations on the safe use of compressed liquids and gases.

ReCoila®'s Quality Statement

All ReCoila® Spring rewind hose cord and cable reels are built with quality in mind. Our in-house quality system requires us to check raw materials and sub-contracted components to ensure they meet the standard of engineering we require in order to offer the best possible product on the market.

During the four stages of manufacturing each sub-assembly is checked to ensure functionality and dimensional correctness.

Specific components such as swivels and slip-rings are checked at the sub-assembly stage and during final assembly to ensure they pass low pressure and high pressure tests. Slip-rings are checked for electrical continuity, earth leakage and insulations test.

A final assembly check is carried out before packing to ensure the reel retracts correctly and the locking system is functioning correctly.

Our in-house quality system is backed by our 12 months extensive warranty should undetected or unforeseen failures occur.

Terms and Conditions of Warranty

The one year Limited Warranty Statement

Strata Group (Aust) Pty Ltd affirms its product confidence with the following warranty.

All products manufactured by Strata Group (Aust) Pty Ltd are warranted to be free of defects in material and workmanship for Twelve (12) months from the date of invoice.

Strata Group (Aust) Pty Ltd's liability shall be limited to repair or replacement of defective material within the warranty period when returned freight paid to its plant or service depot designated by Strata Group (Aust) Pty Ltd.

Our goods come with guarantees that cannot be excluded under the Australian Consumer Law. You are entitled to a replacement or refund for a major failure and compensation for any other reasonably foreseeable loss or damage. You are also entitled to have the goods repaired or replaced if the goods fail to be of acceptable quality and the failure does not amount to a major failure.

The warranty does not cover damage caused by accident, misuse, use in applications other than for which the reel was designed, abuse or faulty installation or normal wear and tear. Strata Group (Aust) Pty Ltd products must be installed and maintained in compliance with the manual of instructions furnished with each reel.

Extended five year Limited Warranty

The listed items have an extended five (5) year limited warranty

- Swivel component - sleeve and shaft.

Extended two year Limited Warranty

The listed items have an extended Two (2) year limited warranty

- Spring and Plastic components.

The one and two year Warranty does not include the following:

Hose - these are warranted by the respective hose manufacturers.

O-rings - are limited to three (3) months.

Installation instructions

Connection of the inlet (supply) hose

A flexible connection between the reel and the source of supply is required to prevent possible misalignment and binding.

Non flexible connections will void the warranty.

The pressure rating of the inlet hose must be equal to or greater than the rating of the reel.

Always check with your local authorities for appropriate rules and regulations for safe use and handling of compressed gases and liquids.

Using the appropriate approved hose and fittings connect the supply line to the inlet connection of the reel.

Ensure you use thread sealants where applicable and permitted.

Never over-tighten or under-tighten fittings.

Once connection has been made to the inlet of the reel ensure you make or fit a connection to the outlet of the reel (the main hose) then turn the supply valve on slowly and check for leaks.

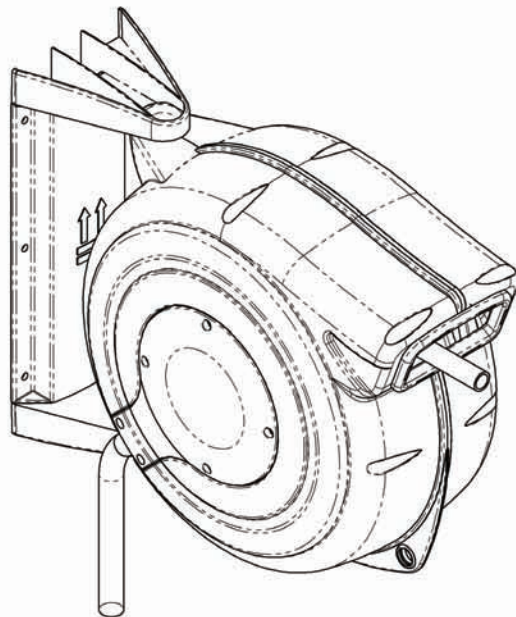

Note: Please refer to your local authority for rules and regulations on the safe use of compressed liquids and gases.

Mounting the reel

All ReCoila[®] Spring rewind hose reels are fitted with an all position locking system which allows the reel to operate in all positions (360 by 360 degrees). The reel is supplied as standard with a mounting system and brackets that allow ceiling mounting or wall mounting

The optimum height for wall mounting is such that it allows the hose or cable to be pulled from the reel without causing undue drag in operation and potentially cause premature wear to the mouth opening of the reel.

Typical mounting

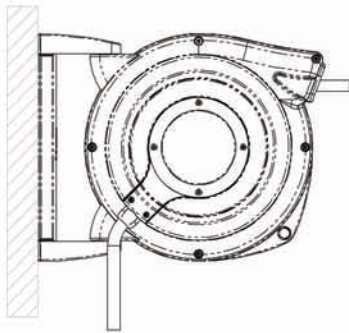

Ceiling mounting

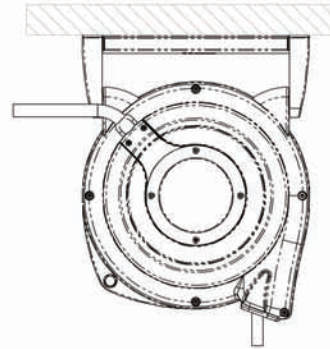

Note: The orientation of the wall brackets is important please follow drawings

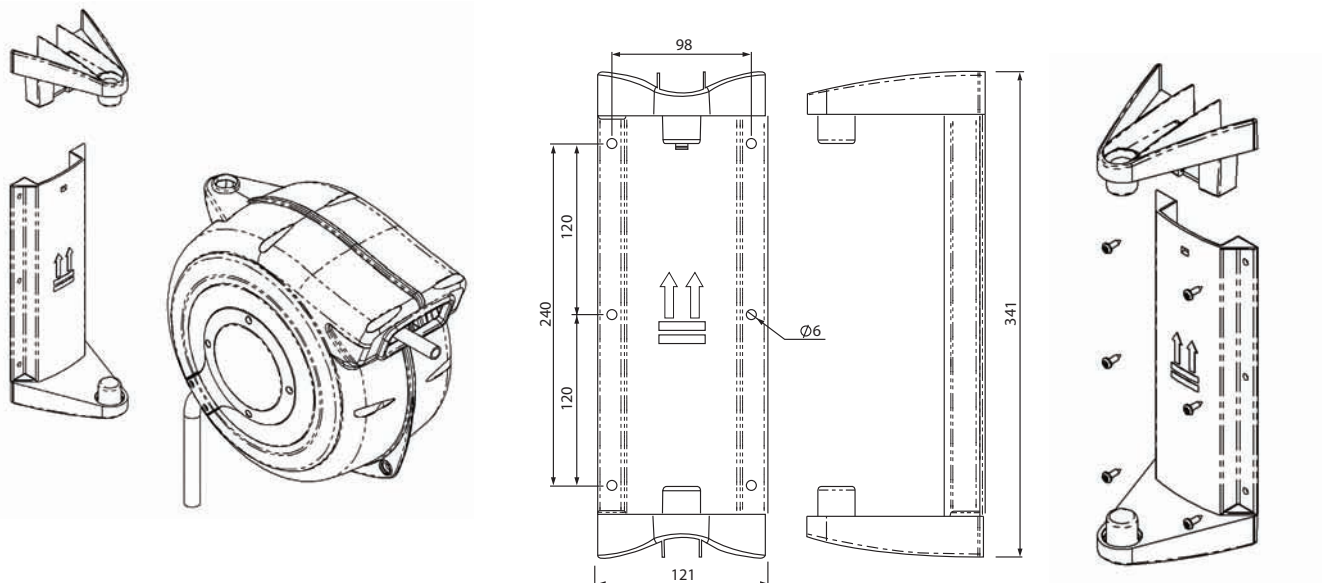

How to use the reel

Once you have mounted your reel and made the inlet connection you are ready for operation. In order to familiarise yourself with the function of the reel stand as close as possible to the reel, pulling the hose slowly out you will note a clicking noise. This is the locking pawl running over the locking teeth or ratchet teeth.

As soon as you hear this noise stop pulling and allow the hose to retract a little and it will lock in position. If it won't lock allow the hose to retract back further then pull it again slowly until you hear the first one or two clicks stop pulling and allow the hose to retract a small amount and it will lock.

Now pull it out some more until you here the next set of clicks and repeat the locking process. The hose will lock at about every foot or 300 mm increment but only after you have been pulling it with an outward movement.

The locking system is designed so that the hose will never lock when rewinding the hose.

Once you are familiar with the system you wont need to listen for the locking clicks as you will automatically know when and where it will lock.

Never let the hose or cable fly back uncontrolled this can cause damage to property or person. Always keep a firm hold of the hose as it is retracting back into the reel.

To rewind the hose pull it out about 1 ft or 300 mm and then allow it to retract back whilst holding the hose. If you want to stop the rewinding and lock it in position again, pull some hose out until you hear the clicking and allow it to retract a little locking the hose in position.

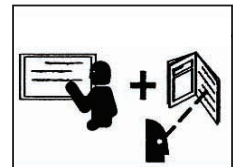

Adding / removing tension

Note: Never add or remove tension when the hose is extended from the reel. The hose must always be fully wound on the hose reel.

Adding tension

With the hose fully recoiled in the reel remove the two most inner self-tapping screws locked on the tension ring. With a "C" spanner or the tensioning service tool rotate the cap clockwise one full turn, the tensioning cap is a ratchet system so you will note the clicking as you rotate the cap. Always have the screws vertical when finished this way you will always know you have a full turn.

Whenever adding tension only ever add one full turn at a time

Before replacing the screws pull the hose out - check to ensure that all the hose comes out. If you cannot pull the hose all the way out and there are remaining coils left on the reel this indicates that you have over-tensioned the spring or that the spring has run out of power and we suggest that you contact your service center.

If all is OK replace the two self-tapping screws to lock the cap in position.

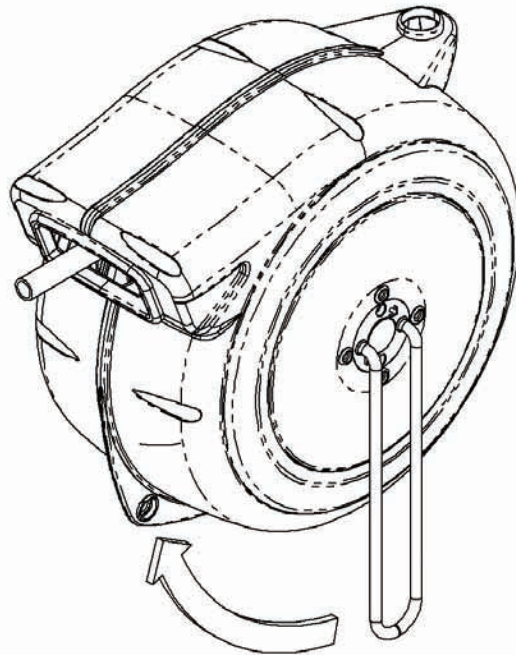

Note: Never add or remove tension when the hose is extended from the reel. The hose must always be fully wound on the hose reel.

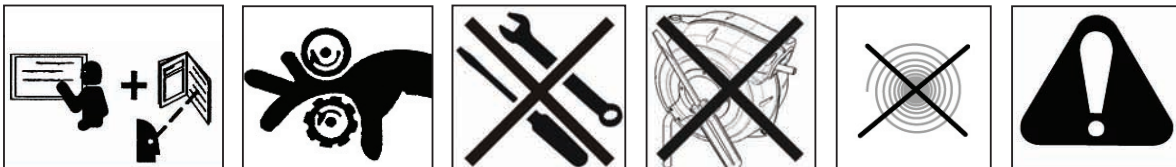

Removing tension

Removing tension is done for one of two reasons, one that you over tensioned your hose reel and cannot pull all the hose out and the second is that you are replacing the spring drum.

There should be no other reason to remove tension from the reel.

Using a "C" spanner or the service tool hold the center locking cap and remove the four outer screws.

Note: There is tension on this cap and it will want to spin anticlockwise so hold tightly.

Once the screws are removed allow the cap to unwind in a controlled manner - once the tension is released the cap will sit stationary.

This has now released all the tension.

Replace the four self-tapping screws ensuring you locate the correct position between the inner rotating cap and the side plate.

To add tension follow the steps under "Adding tension". If you have removed all the tension and are re-tensioning add two full turns to start with and then one more at a time if necessary.

Repeat the steps as described in "Adding tension".

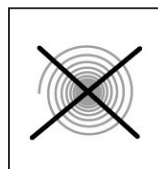
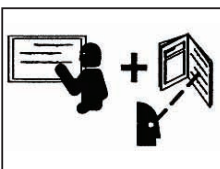
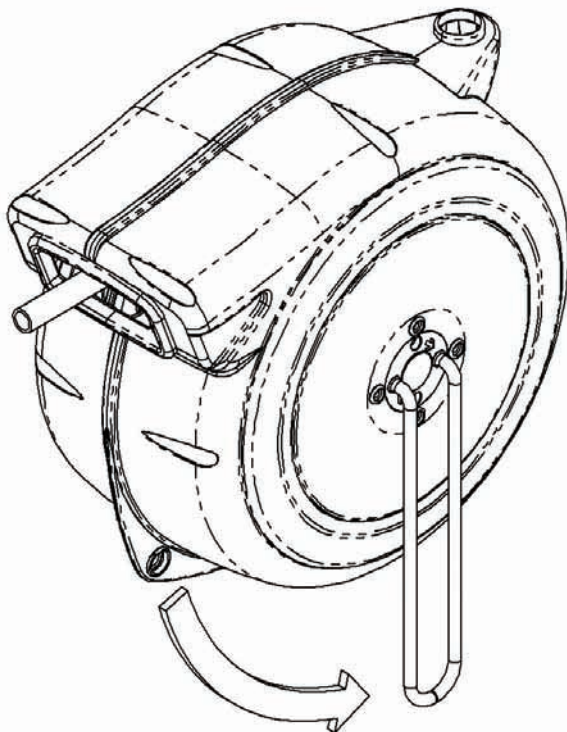

Typical main assembly

Air water

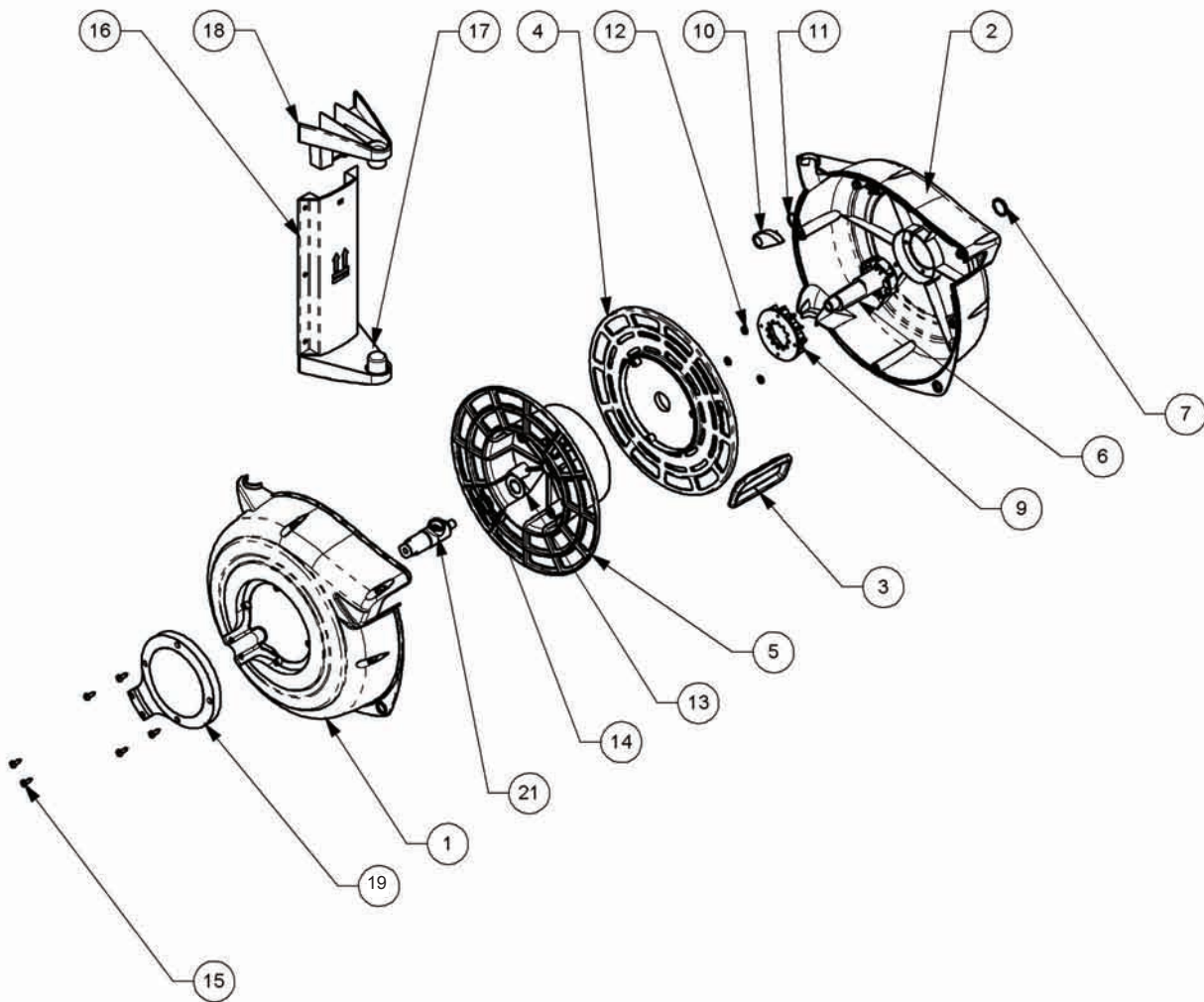

Note: Not all items are sold as individual parts - complex assemblies and spring assemblies are sold in sub-assembly kit form.

Note: Use only ReCoila[®] original components failure to do so will void warranty.

Electrical assembly

Note: If the supply cord or slip-ring is damaged, any repairs to electrical cable reels should be carried out by ReCoila or ReCoila's authorised service centre or similarly qualified persons in order to avoid a hazard.

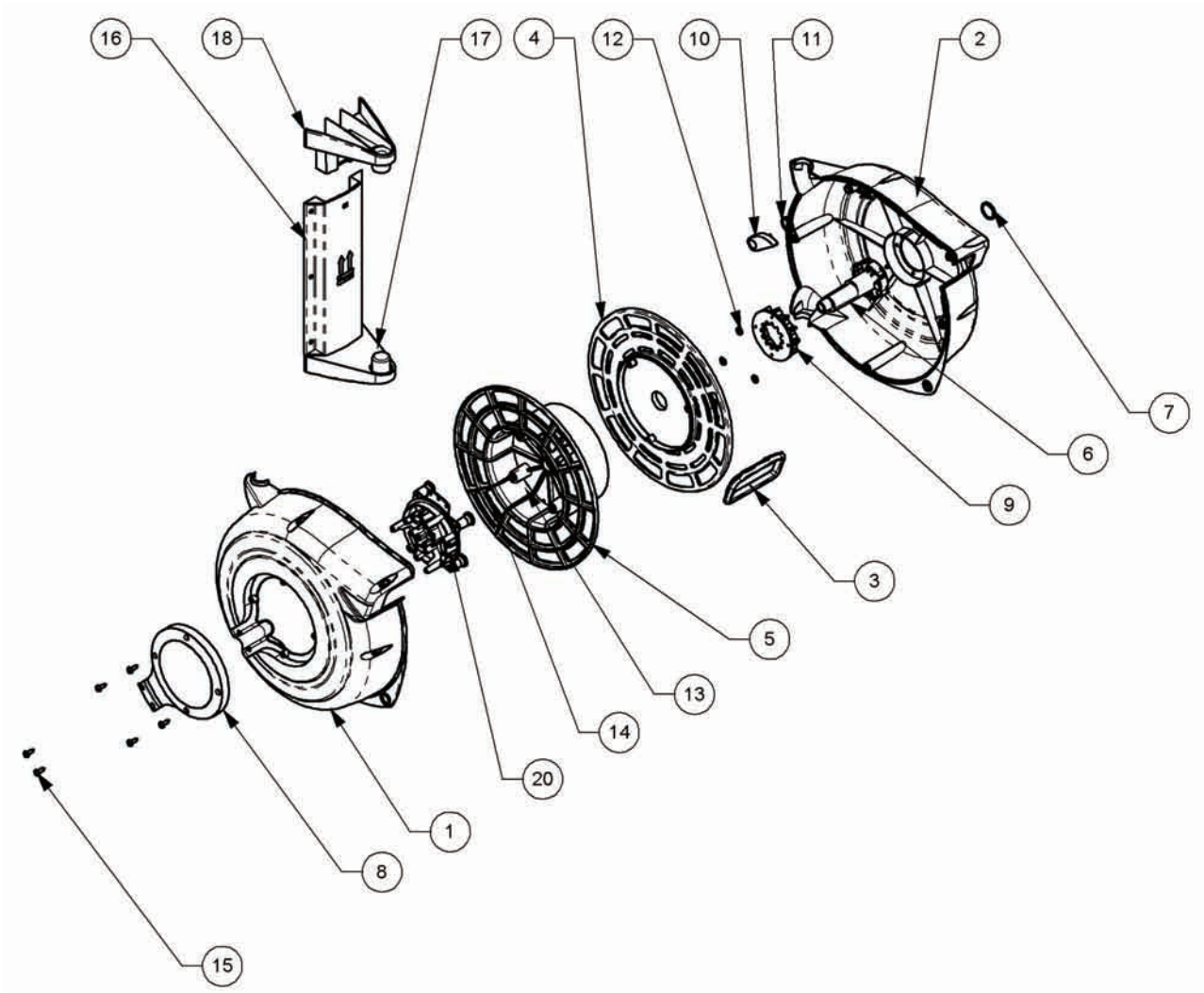

Note: Not all items are sold as individual parts - complex assemblies and spring assemblies are sold in sub-assembly kit form.

Note: Use only ReCoila® original components failure to do so will void warranty.

Numerical part numbers

Item n/o	Ordering code	Description
1	S10005	Outer case inlet side
2	S10006	Outer case tension side
3	S10011	Mouth guard
4	#	Drum flange tension side
5	#	Drum flange inlet side
6	S10009	Spring arbour main shaft
7	S10017	Cap
8	S10014	Inlet side plate electrical
9	SG0407	Tension ring
10	S10010	Ratchet pawl
11	#	Push on clip pawl
12	S10015	Push on fasteners tension ring
13	#	Arbour washer
14	#	Arbour push on fastener
15	SG0260	Side plate fastener
16	#	Wall bracket body
17	#	Wall bracket lower arm
18	#	Wall bracket upper arm
19	S10013	Inlet side plate air water reel
20	#	Electrical slip ring assembly
21	#	Air and water swivel assembly

#Denotes supplied in an assembly see below

Assembly and kit components

	SG0042	Hose bumper 6-mm
	SG0017	Hose bumper 10-mm
	SG0040	Hose bumper 12-mm
	SG0041	Hose bumper 8-mm
4,5	SG10007	Drum and spring assembly
16,17,18	SG10012	Wall bracket assembly
20	SG10020	Air and water swivel
21	SG10004	Electrical slip ring assembly
	S10036	Operation and instruction manual

Contact Us

Head Office Australia

Postal address:

PO BOX 641 Main Street
Blacktown NSW 2148
Australia

Phone

(61) 2 9621 8988

Email

sales@recoila.com.au

Street address:

Unit 1/10 Melissa Place
Kings Park NSW 2148
Australia

Fax

(61) 2 9621 7688

Web

www.recoila.com.au

Office New Zealand

Postal address:

P.O. BOX 101 582
North Shore Mail Centre
Auckland
New Zealand 0745

Phone

(64) 9 4410177

Email

sales@recoila.co.nz

Street address:

Unit 1/A 93 Ellice Rd
Glenfield
Auckland
New Zealand 0745

Fax

(64) 9 4410178

Web

www.recoila.co.nz