

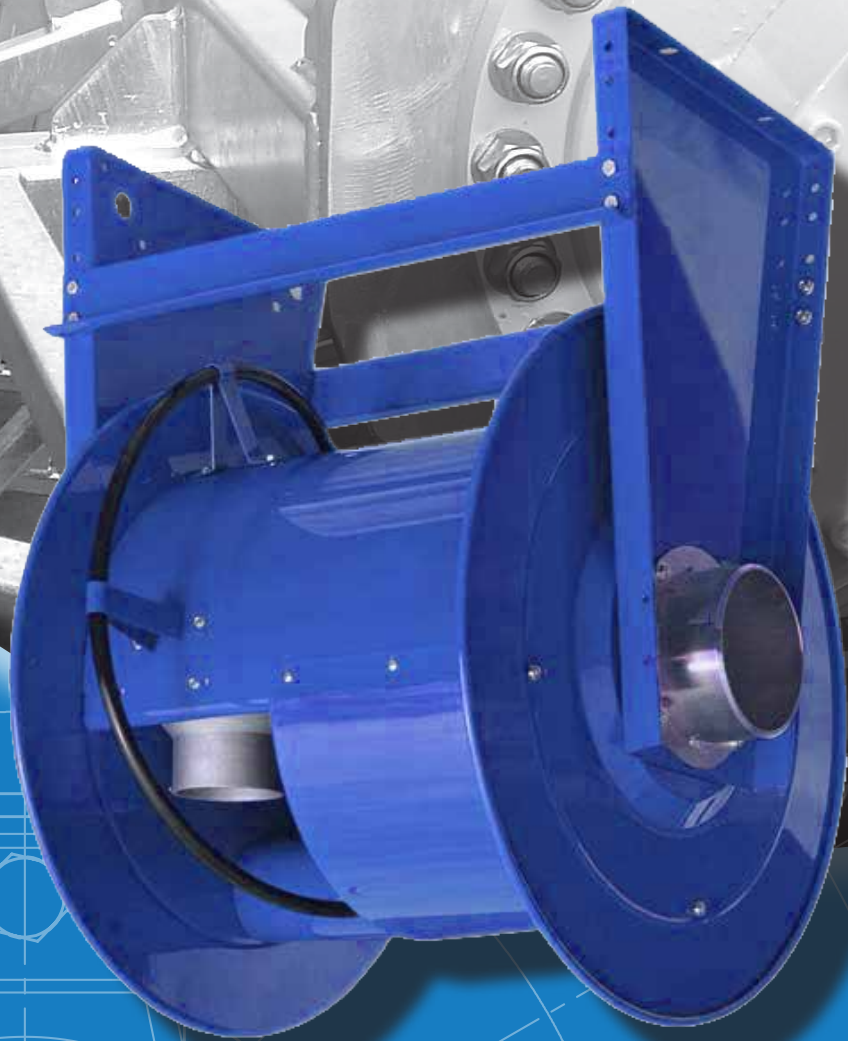

# ReCoila

HOSE AND CORD REELS

## EXHAUST REELS



30°



# HOSE REELS.

Our total, dedicated business.

We've been making hose reels for decades - over 38 years in fact - and this manufacturing wisdom, coupled with competitive pricing, knowledgeable staff, a wealth of technical information and solid after-sales service positions us firmly at the forefront of our industry.

Our head office and factory is based in Sydney Australia, with a well-stocked distribution centre in Auckland NZ, as well as reputable distribution partners across the globe.

ReCoila has a fully equipped production facility and a team of experts to ensure our reels are designed and manufactured to exacting standards.

With a comprehensive range of hose, cord and cable reels and a dedicated custom design and manufacturing team, ReCoila can supply the right reel for your individual application - with safety and productivity in mind.

## AUSTRALIAN MANUFACTURING. INTERNATIONAL DISTRIBUTION.

ReCoila is a proudly Australian company based in Western Sydney, with distribution reach across Australia, New Zealand and internationally.

We have resellers strategically based in key metro and regional areas to ensure delivery to customers is as swift as possible, and long standing relationships with our freight carriers mean that logistics are coordinated efficiently.

## AUSTRALIAN MADE + QUALITY IMPORTS = COMPREHENSIVE RANGE.

Our range constitutes a wealth of engineered polypropylene and heavy duty steel and stainless steel reels, supplemented with hand-picked reels from some of the world's best manufacturers, to present a truly comprehensive product portfolio. And, our ability to design and manufacture customised reels in-house means that we're sure to have a reel to suit your needs.



VISIT  
RECOILA  
ONLINE





# SPECIALISTS IN CUSTOM REELS

## 38+ years manufacturing wisdom

ReCoila is committed to continued quality and engineering excellence, coupled with real-world practicality and constant improvement based on feedback from customers.

Our goal has always been to design the best reels in the world - and we think we're pretty close to the mark.

With teams of specialists for both steel and polypropylene production, we continue to lead the way in design, innovation, functionality & reliability.

### WE KNOW REELS – YOU KNOW YOUR BUSINESS.

Whilst we've been building reels for over thirty years, we continue to learn and adapt to individual industry challenges in consultation with our customers.

We have worked with Australian and New Zealand fire brigades, Australian Defence forces, major international mining and resources projects, salmon farms, airports, oil rigs, gas exploration companies, plumbers, truck builders, food manufacturers, wineries, auto workshops, universities and electricity providers, and have built reels to transfer everything from clean air to cow dung.

Our collaborative approach has always resulted in a hose reel that is of the highest quality, whilst being simple, practical and effective for the people in the field who are actually operating it.

## THE MAKING OF A CUSTOM HOSE REEL



# EXHAUST REELS

Safe, dependable, versatile

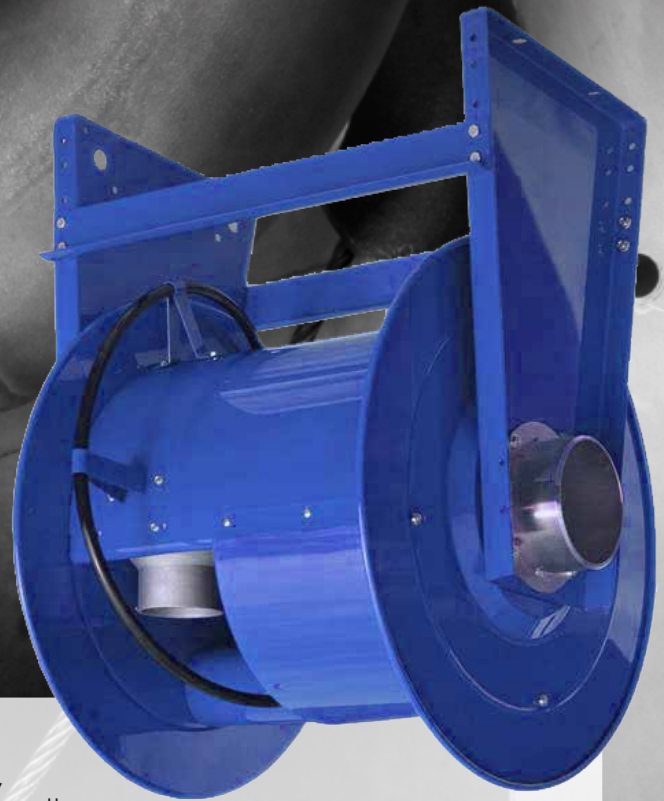

Perfect for mechanics, diesel repair shops, auto dealers, truck dealers and bus depots, ReCoila's exhaust reels conveniently store lengths of exhaust hose up to 8" ID.

Designed to divert hazardous carbon monoxide gases away from the workplace, these industrial strength reels are spring retractable and feature a latching mechanism that maintains the desired length of hose.

Proper installation eliminates hazardous carbon monoxide gases in the workplace. The reel may be mounted to the ceiling, wall or floor, and is highly corrosion resistant with individually powder coated parts.

## V SERIES EXHAUST REELS

### APPLICATION

Designed specifically for use in auto workshops to divert carbon monoxide via large diameter hose. Features two industrial strength carbon drive springs to ensure the hose retracts every time. Can be mounted on the ceiling, floor or wall.

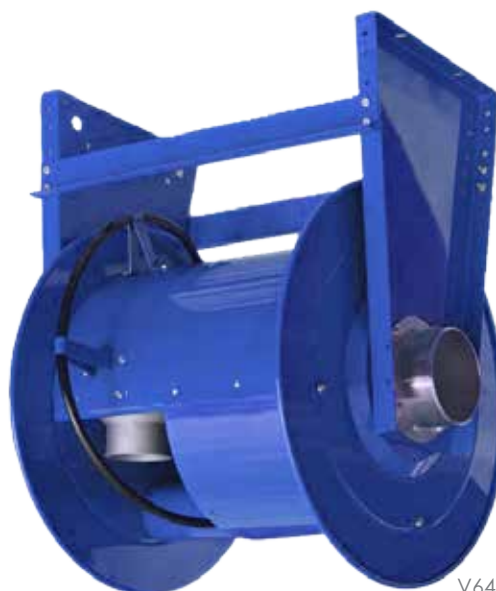

V648-04-01-00

**HOSE TYPE** Supplied without hose. Suits 4" to 8" hose (see table)

**MEDIA** Carbon monoxide

**CONSTRUCTION MATERIAL** Steel

**FINISH** Powder coated

**FITTING TYPE** Supplied with inlet & hose adapter to match hose ID

### FEATURES



### DIMENSIONS

REFER TO TABLE

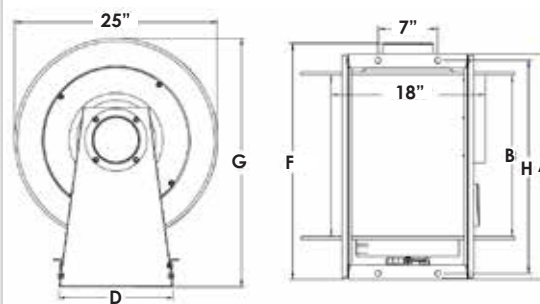

### V SERIES EXHAUST REELS

Model	Length (m)	Hose ID		Weight (kg)	Dimensions (inches)					
		(mm)	(inches)		A	B	D	F	G	H
V419-02-01-00	7	102	4	51	24.25	19	14	27.75	31	25
V428-02-01-00	10	102	4	56	35.25	28	14	36.75	31	34
V432-02-01-00	12	102	4	60	39.25	32	14	40.75	31	38
V519-02-01-00	5	127	5	51	24.25	19	14	27.75	31	25
V528-02-01-00	8	127	5	56	35.25	28	14	36.75	31	34
V532-02-01-00	9	127	5	60	39.25	32	14	40.75	31	38
V619-05-01-00	5	152	6	51	24.25	19	14	27.75	31	25
V628-02-01-00	7	152	6	56	35.25	28	14	36.75	31	34
V632-02-01-00	8	152	6	60	39.25	32	14	40.75	31	38
V648-04-01-00	12	152	6	76	55.25	48	14	43.75	31	54
V832-04-01-00	6	203	8	78	39.25	32	15	43.5	33.75	38
V848-04-01-00	9	203	8	87	55.25	48	15	59.5	33.75	54
600138 - Hose bumper accessory					Suits 4" to 8" hose					



# STAY IN TOUCH

News and updates



**RECOILA ON LINKED IN**  
[linkedin.com/company/  
recoila-hose-and-cord-reels](https://linkedin.com/company/recoila-hose-and-cord-reels)



**JOIN OUR MAILING LIST**  
Visit [recoila.com.au](https://recoila.com.au) and click  
**GET UPDATES** in the main menu



**LIKE US ON FACEBOOK**  
[facebook.com/Recoila](https://facebook.com/Recoila)



**VISIT OUR WEBSITE**  
[recoila.com.au](https://recoila.com.au)

LEARN MORE



**RECOILA AUSTRALIA - HEAD OFFICE**  
Unit 1/10 Melissa Place  
Kings Park NSW 2148  
Australia

Phone +61 2 9621 8988  
Fax +61 2 9621 7688  
sales@recoila.com.au

**RECOILA NEW ZEALAND**  
18 Maui Street, Pukete  
Hamilton 3200  
New Zealand

Phone +64 7 847 4111  
Fax +64 7 847 4112  
sales@recoila.co.nz

[www.recoila.com.au](http://www.recoila.com.au)

[www.recoila.co.nz](http://www.recoila.co.nz)

VISIT  
RECOILA  
ONLINE

