



Recoila

HOSE AND CORD REELS

TOOL BALANCERS



30°



HOSE REELS.

Our total, dedicated business.

We've been making hose reels for decades - over 38 years in fact - and this manufacturing wisdom, coupled with competitive pricing, knowledgeable staff, a wealth of technical information and solid after-sales service positions us firmly at the forefront of our industry.

Our head office and factory is based in Sydney Australia, with a well-stocked distribution centre in Auckland NZ, as well as reputable distribution partners across the globe.

ReCoila has a fully equipped production facility and a team of experts to ensure our reels are designed and manufactured to exacting standards.

With a comprehensive range of hose, cord and cable reels and a dedicated custom design and manufacturing team, ReCoila can supply the right reel for your individual application - with safety and productivity in mind.

AUSTRALIAN MANUFACTURING. INTERNATIONAL DISTRIBUTION.

ReCoila is a proudly Australian company based in Western Sydney, with distribution reach across Australia, New Zealand and internationally.

We have resellers strategically based in key metro and regional areas to ensure delivery to customers is as swift as possible, and long standing relationships with our freight carriers mean that logistics are coordinated efficiently.

AUSTRALIAN MADE + QUALITY IMPORTS = COMPREHENSIVE RANGE.

Our range constitutes a wealth of engineered polypropylene and heavy duty steel and stainless steel reels, supplemented with hand-picked reels from some of the world's best manufacturers, to present a truly comprehensive product portfolio. And, our ability to design and manufacture customised reels in-house means that we're sure to have a reel to suit your needs.



VISIT
RECOILA
ONLINE



SPECIALISTS IN CUSTOM REELS

38+ years manufacturing wisdom

ReCoila is committed to continued quality and engineering excellence, coupled with real-world practicality and constant improvement based on feedback from customers.

Our goal has always been to design the best reels in the world - and we think we're pretty close to the mark.

With teams of specialists for both steel and polypropylene production, we continue to lead the way in design, innovation, functionality & reliability.

WE KNOW REELS – YOU KNOW YOUR BUSINESS.

Whilst we've been building reels for over thirty years, we continue to learn and adapt to individual industry challenges in consultation with our customers.

We have worked with Australian and New Zealand fire brigades, Australian Defence forces, major international mining and resources projects, salmon farms, airports, oil rigs, gas exploration companies, plumbers, truck builders, food manufacturers, wineries, auto workshops, universities and electricity providers, and have built reels to transfer everything from clean air to cow dung.

Our collaborative approach has always resulted in a hose reel that is of the highest quality, whilst being simple, practical and effective for the people in the field who are actually operating it.

THE MAKING OF A CUSTOM HOSE REEL



TOOL BALANCERS

For a safer, more ergonomic workplace



Tool balancers make tools nearly weightless, reducing operator fatigue.

These compact reels improve safety and ergonomics and help prevent tools from being accidentally dropped, thus reducing tool damage.

TB SERIES STEEL TOOL BALANCERS

APPLICATION

Balances the weight of assembly tools, making them nearly weightless thereby reducing operator fatigue. Note that a safety cable is strongly recommended - a secondary cable or steel link chain prevents the balancer from accidental falls. Balancers have extra holes for safety cable or chain.

CABLE TYPE Nylon covered steel cable with safety clip

FITTING 60mm zinc plated steel safety latch for tool attachment

CONSTRUCTION MATERIAL Steel

FEATURES

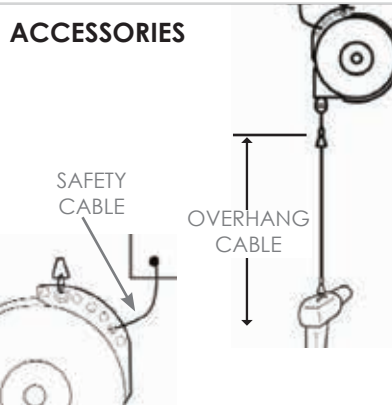

TB SERIES MEDIUM DUTY

Model	Min - Max Load (kg)	Cable Length (m)	Reel Weight (kg)	Ratchet lock
TB01	0.0 - 0.7kg	1.8	0.5	No
TB03	0.7 - 1.4kg	1.8	0.6	No
TB05	1.4 - 2.3kg	1.8	0.7	No

TB SERIES HEAVY DUTY

Model	Min - Max Load (kg)	Cable Length (m)	Reel Weight (kg)	Ratchet lock
TB10	0.0 - 0.7kg	2.4	1.5	No
TB12	0.7 - 1.4kg	2.4	4.5	No
TB15	4.5 - 6.8kg	2.4	4.5	No
TB23	7.2 - 10.4kg	2.4	4.5	No

TB SERIES HEAVY DUTY WITH RATCHET LOCK

Model	Min - Max Load (kg)	Cable Length (m)	Reel Weight (kg)	Ratchet lock
TBL10	2.3 - 4.5kg	2.4	2.7	Yes
TBL12	3.6 - 5.4kg	2.4	3.1	Yes
TBL15	4.5 - 6.8kg	2.4	3.6	Yes
TBL23	7.2 - 10.4kg	2.4	3.6	Yes

Cable lengths listed are 'active' or 'working' cable. Safety tool clip and cable stop included.



DIMENSIONS

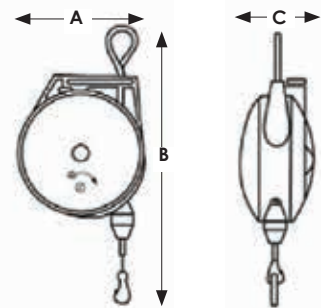

	MEDIUM DUTY	HEAVY DUTY
A	102mm	222mm
B	235 to 1473mm (max)	532 to 2286mm (max)
C	73mm	85mm

OVERHANG CABLE

Model	Cable Length (cm)	Type
600605-3	91.5cm	Nylon covered steel
600605-5	152.4cm	Nylon covered steel

SAFETY CABLE

Model	Cable Length (cm)	Type
600603	30.5cm	Nylon covered steel

SAFETY CHAIN

Model	Cable Length (cm)	Type
600604	30.5cm	Steel link chain

TBA SERIES ALUMINIUM TOOL BALANCERS

APPLICATION

Designed to sustain manual tools - an essential aid for production work, assembly and packaging. Manufactured from high quality die-cast aluminium.

CABLE TYPE	Inox steel
FITTING	Karabiner
CONSTRUCTION MATERIAL	Die-cast aluminium

FEATURES



SPIRAL HOSE ACCESSORY



DIMENSIONS

	TBA630 - TBA632	TBA633 - TBA637
A	250	415
B	113	192
C	93	162.5
D	60	99.5
E	8	10
F	6	8

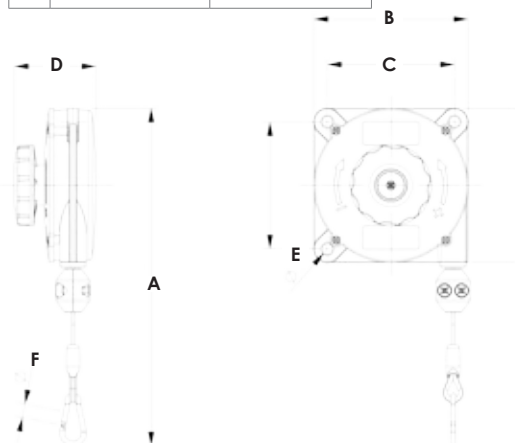

TBA SERIES

Model	Min - Max Load (kg)	Cable Length (m)	Reel Weight (kg)	Can be used with spiral hose accessory
TBA630	0.4 - 1kg	1.6	0.63	Yes
TBA631	1 - 2kg	1.6	0.67	Yes
TBA632	2 - 3kg	1.6	0.79	Yes

TBA SERIES WITH ANTI-FALL DEVICE

TBA633	2 - 4kg	2.5	2.8	No
TBA634	4 - 6kg	2.5	3	No
TBA635	6 - 8kg	2.5	3.1	No
TBA636	8 - 10kg	2.5	3.2	No
TBA637	10 - 14kg	2.5	3.5	No

SPIRAL HOSE ACCESSORY

TBA982	Spiral hose for tool balancers - supplied with an additional metre of hose for connection to compressed air network and tool. Suits 10 max bar pressure, working temperature -20 / +80°C
--------	--

Cable lengths listed are 'active' or 'working' cable. Safety tool clip and cable stop included.

STAY IN TOUCH

News and updates



RECOILA ON LINKED IN
[linkedin.com/company/
recoila-hose-and-cord-reels](https://www.linkedin.com/company/recoila-hose-and-cord-reels)



JOIN OUR MAILING LIST
Visit [recoila.com.au](https://www.recoila.com.au) and click
GET UPDATES in the main menu



LIKE US ON FACEBOOK
[facebook.com/Recoila](https://www.facebook.com/Recoila)



VISIT OUR WEBSITE
[recoila.com.au](https://www.recoila.com.au)

LEARN MORE



RECOILA AUSTRALIA - HEAD OFFICE
Unit 1/10 Melissa Place
Kings Park NSW 2148
Australia

Phone +61 2 9621 8988
Fax +61 2 9621 7688
sales@recoila.com.au

RECOILA NEW ZEALAND
18 Maui Street, Pukete
Hamilton 3200
New Zealand

Phone +64 7 847 4111
Fax +64 7 847 4112
sales@recoila.co.nz

www.recoila.com.au

www.recoila.co.nz

VISIT
RECOILA
ONLINE

