

Forklift Recharging Reels

ReCoila® Gen III ELDC series reels offers an ideal solution for managing forklift recharging cables. Overheating cables and poor recharges are generally a result of damaged cables and connections from being left laying around. Installing a recharge reel will not only increase the life expectancy of the cables and connectors but will make the operation of recharging more efficient and offer a safer tidier work area.

Model	Cable mm ²	Cable Length	No. Cores	Inlet	VDC	Amps	Outlet	Weight
ELDC650	16mm ²	5m	2	Plug	600	50	Socket	12Kg
ELDC6175	16mm ²	5m	2	Plug	600	175	Socket	12Kg
ELDC6350	16mm ²	5m	2	Plug	600	350	Socket	12Kg

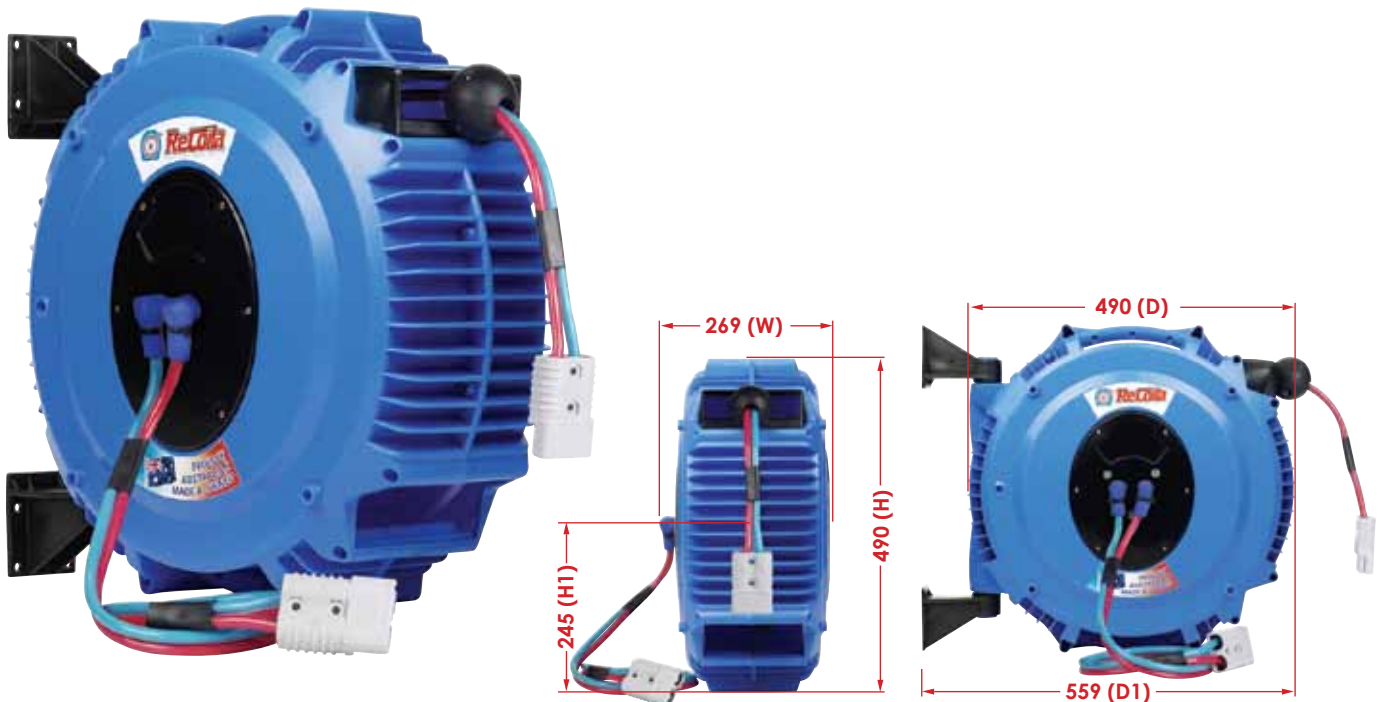

Note:
Slip ring rating 600 VDC @ 350 Amps. To be used with cable fully uncoiled.

Gen III Features & Benefits

ReCoila® Gen III composite construction reels lead the world in design, functionality, reliability and innovative features.

ReCoila® was one of the first in the world to develop and manufacture composite spring rewind reels and today we continue to be world leaders.

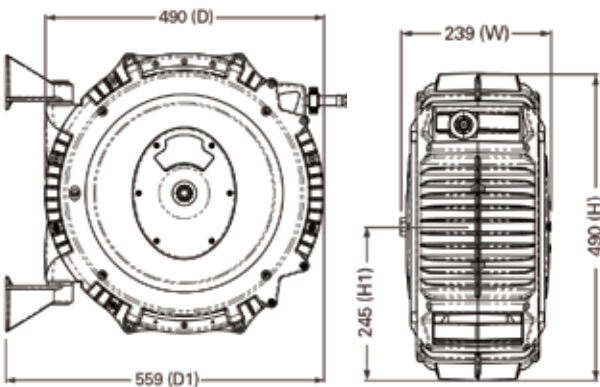

- Up to a 5 year warranty
- Highest quality 'finished edge' spring steel strip
- Full flow swivels and fluid paths
- Positive crimp hose fittings
- All position positive latching system
- Tough, impact, corrosion resistant and UV stabilized polypropylene with anti static and flame retardants
- Unique ratchet tensioning system
- Heavy Duty wall mounting swivel system
- Replaceable protective mouth guard
- Large side covers for easy access in servicing and maintenance routines
- Food grade approved materials
- Unique service locking pin port for added safety
- Two part fully adjustable bumper
- Detailed operation and service manual
- Easy mount drill hole pattern supplied

