

## Safety Barrier Reels

Fitted with 15m of 50mm wide woven webbing (safety orange) or 15m of polyurethane chain (safety yellow) the ReCoila® Barrier Reels are the ideal way to quickly & efficiently set up personnel safety barriers for areas that require regular guarding. Additionally these reels are widely used to cordon off roller doors that are required to be open for light and air movement and frequent traffic however need to be restricted access.

| Model   | Webbing Width | Webbing Length | End Fitting | Weight |
|---------|---------------|----------------|-------------|--------|
| BAR5015 | 50mm          | 15m            | Sewn loop   | 12Kg   |

| Model  | Chain Dimension | Chain Length | End Fitting | Weight |
|--------|-----------------|--------------|-------------|--------|
| BARC15 | 6mm x 36mm      | 15m          | Link        | 12Kg   |

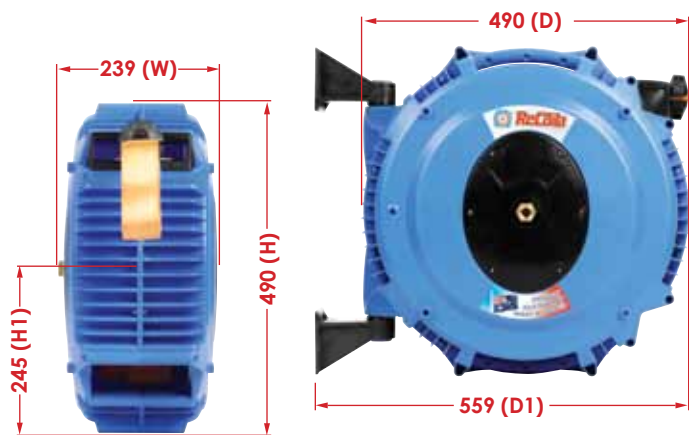

## Gen III Features & Benefits

ReCoila® Gen III composite construction reels lead the world in design, functionality, reliability and innovative features.

ReCoila® was one of the first in the world to develop and manufacture composite spring rewind reels and today we continue to be world leaders.

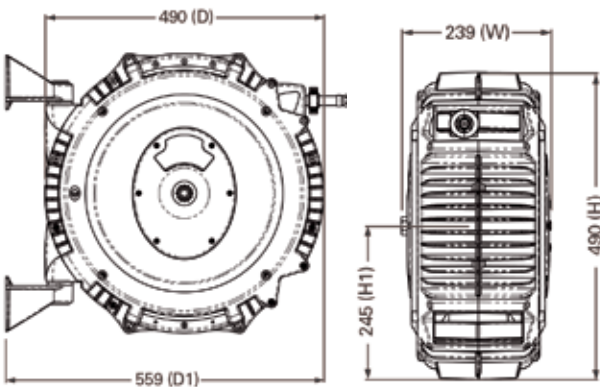

- Up to a 5 year warranty
- Highest quality 'finished edge' spring steel strip
- Full flow swivels and fluid paths
- Positive crimp hose fittings
- All position positive latching system
- Tough, impact, corrosion resistant and UV stabilized polypropylene with anti static and flame retardants
- Unique ratchet tensioning system
- Heavy Duty wall mounting swivel system
- Replaceable protective mouth guard
- Large side covers for easy access in servicing and maintenance routines
- Food grade approved materials
- Unique service locking pin port for added safety
- Two part fully adjustable bumper
- Detailed operation and service manual
- Easy mount drill hole pattern supplied

