

Electrical Cord Reels

ReCoila® Gen III EL series reels are the perfect solution to ensuring cables and cords are stored safely when not in use. When cables and cords are left laying around they are easily damaged resulting in a potential electrocution. Protect your equipment and personnel by installing and using ReCoila® cable and cord reels.

Model	Cable mm ²	Cable Length	No. Cores	Inlet	VAC	Amps	Outlet	Weight
EL2402010	0.9mm ²	20m	3	Plug	240	10	Socket	12Kg
EL2402015	1.5mm ²	20m	3	Plug	240	15	Socket	12Kg
EL4152010	2.4mm ²	20m	4	*N/S	415	10	*N/S	12Kg
EL4152015	2.4mm ²	20m	4	*N/S	415	15	*N/S	12Kg
EL4152020	2.4mm ²	20m	4	*N/S	415	20	*N/S	12Kg
EL4152032	4mm ²	20m	4	*N/S	415	32	*N/S	12Kg

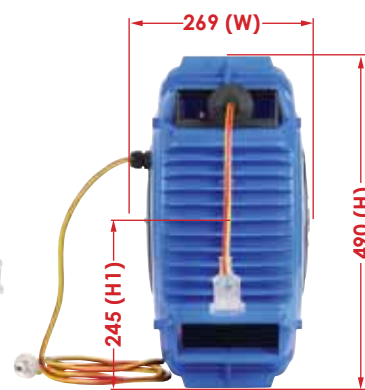

Note:

EL2402010 certified to AS3105. All electrical reels are manufactured in accordance with Australian Electrical Standard AS3105.

*N/S = Not supplied. Other voltages such as 110, 115, 220, 440, 560, VAC, available on request.



Gen III Features & Benefits

ReCoila® Gen III composite construction reels lead the world in design, functionality, reliability and innovative features.

ReCoila® was one of the first in the world to develop and manufacture composite spring rewind reels and today we continue to be world leaders.

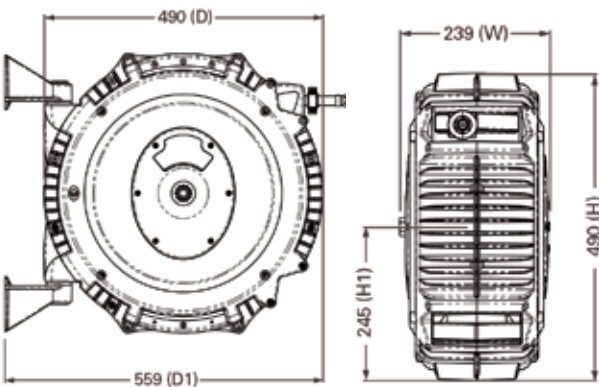

- Up to a 5 year warranty
- Highest quality 'finished edge' spring steel strip
- Full flow swivels and fluid paths
- Positive crimp hose fittings
- All position positive latching system
- Tough, impact, corrosion resistant and UV stabilized polypropylene with anti static and flame retardants
- Unique ratchet tensioning system
- Heavy Duty wall mounting swivel system
- Replaceable protective mouth guard
- Large side covers for easy access in servicing and maintenance routines
- Food grade approved materials
- Unique service locking pin port for added safety
- Two part fully adjustable bumper
- Detailed operation and service manual
- Easy mount drill hole pattern supplied

