

Food Gases Reels

ReCoila® Gen III FD series are primarily designed for use in wineries to dispense CO2 and or Nitrogen gases to blanket the vats and tanks during transfer, storage, fermentation and other processes. Also suited to other food processing industries that require inert gas transfer.

Model	Hose ID	Hose Length	Max PSI	Inlet Fitting	Outlet Fitting	Temp Range	Weight
FD620	6mm	20m	240	3/8" BSPF	1/4" BSPM	-30/+65°C	12Kg
FD820	8mm	20m	240	3/8" BSPF	3/8" BSPM	-30/+65°C	12Kg
FD1020	10mm	20m	240	3/8" BSPF	3/8" BSPM	-30/+65°C	12Kg
High Pressure Non Food Grade Model							
N1015	10mm	15m	600	3/8" BSPF	3/8" BSPM	-30/+90°C	12Kg

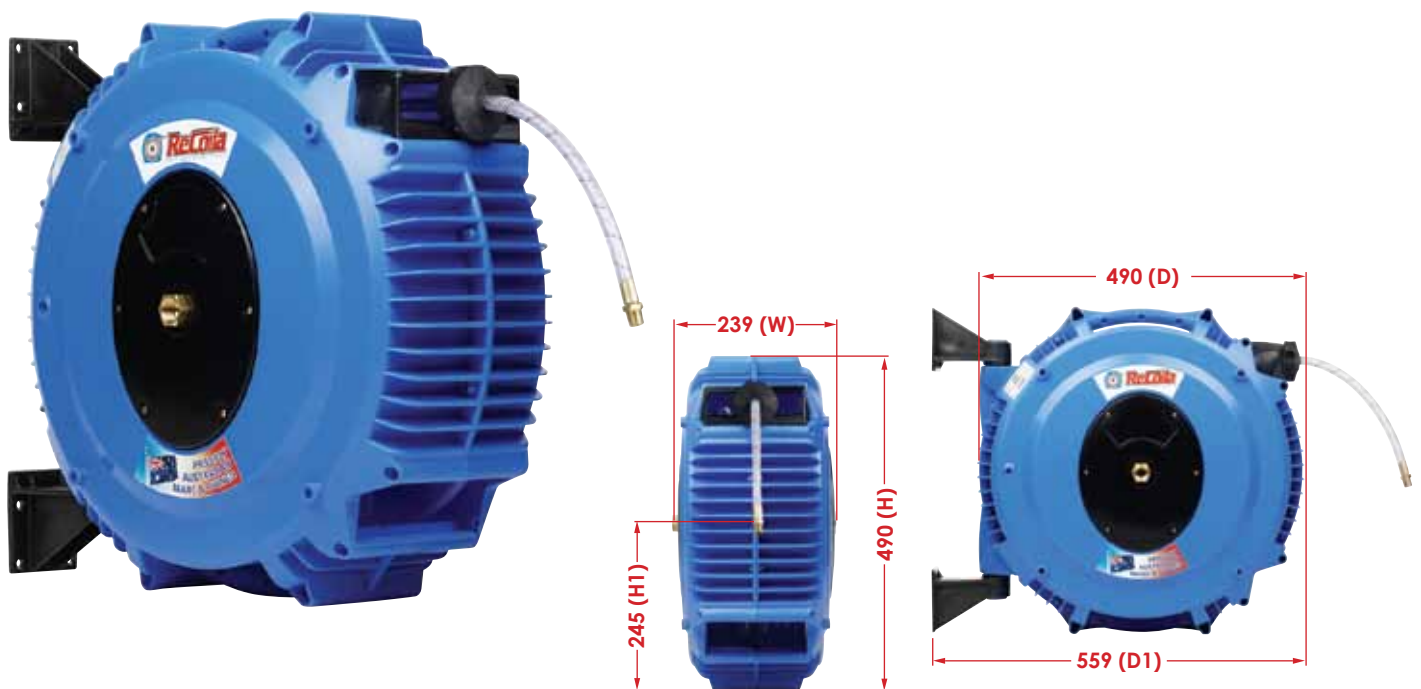

Note:
NPT, JIC, JIS, Metric threads are available on request. Maximum working pressure of the hose is based @ 30°C.

Gen III Features & Benefits

ReCoila® Gen III composite construction reels lead the world in design, functionality, reliability and innovative features.

ReCoila® was one of the first in the world to develop and manufacture composite spring rewind reels and today we continue to be world leaders.

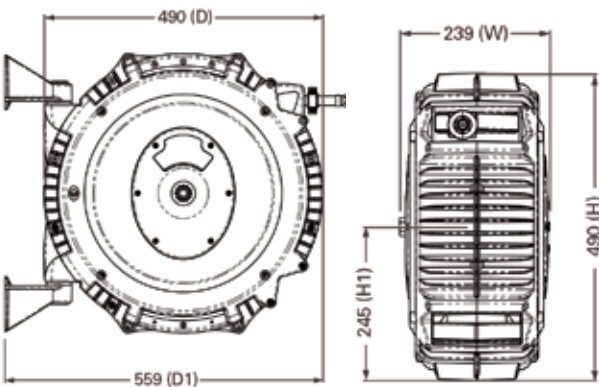

- Up to a 5 year warranty
- Highest quality 'finished edge' spring steel strip
- Full flow swivels and fluid paths
- Positive crimp hose fittings
- All position positive latching system
- Tough, impact, corrosion resistant and UV stabilized polypropylene with anti static and flame retardants
- Unique ratchet tensioning system
- Heavy Duty wall mounting swivel system
- Replaceable protective mouth guard
- Large side covers for easy access in servicing and maintenance routines
- Food grade approved materials
- Unique service locking pin port for added safety
- Two part fully adjustable bumper
- Detailed operation and service manual
- Easy mount drill hole pattern supplied

