

## Lubrication Hose Reels

ReCoila® Gen III OL and GR series reels are the ideal solution for light duty oil and grease transfer applications.

Model	Hose ID	Hose Length	Max PSI	Inlet Fitting	Outlet Fitting	Temp Range	Weight
GR615	6mm	15m	5000	1/4" NPTF	1/4" BSPM	-30/+90°C	12Kg
OL1015	10mm	15m	1200	3/8" BSPF	3/8" BSPM	-30/+90°C	12Kg
OL1210	12mm	10m	1200	1/2" BSPF	1/2" BSPM	-30/+90°C	12Kg

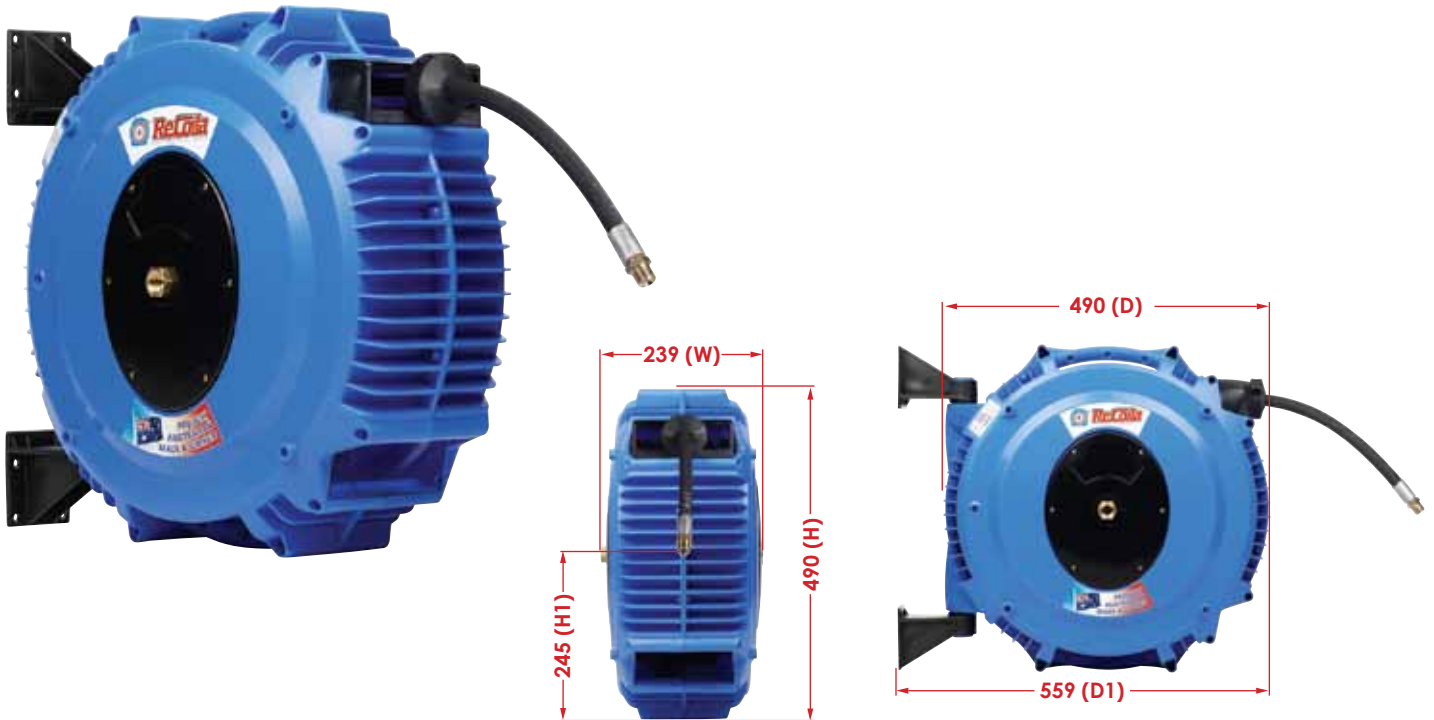

**Note:**

NPT, JIC, JIS, Metric threads are available on request.  
Maximum working pressure of the hose is based @ 30°C.

## Gen III Features & Benefits

ReCoila® Gen III composite construction reels lead the world in design, functionality, reliability and innovative features.

ReCoila® was one of the first in the world to develop and manufacture composite spring rewind reels and today we continue to be world leaders.

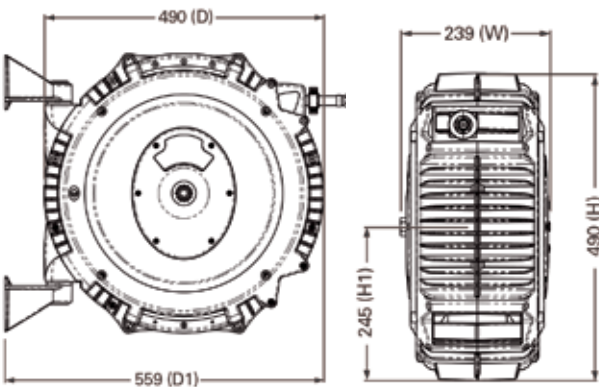

- Up to a 5 year warranty
- Highest quality 'finished edge' spring steel strip
- Full flow swivels and fluid paths
- Positive crimp hose fittings
- All position positive latching system
- Tough, impact, corrosion resistant and UV stabilized polypropylene with anti static and flame retardants
- Unique ratchet tensioning system
- Heavy Duty wall mounting swivel system
- Replaceable protective mouth guard
- Large side covers for easy access in servicing and maintenance routines
- Food grade approved materials
- Unique service locking pin port for added safety
- Two part fully adjustable bumper
- Detailed operation and service manual
- Easy mount drill hole pattern supplied

