

## Air & Water Reels

ReCoila® Gen III AW series reels are the perfect solution for general workshop applications such as compressed air and cold water washdown.

Model	Hose ID	Hose Length	Max PSI	Inlet Fitting	Outlet Fitting	Temp Range	Weight
AW815	8mm	15m	240	3/8" BSPF	3/8" BSPM	-5/+65°C	11Kg
AW820	8mm	20m	240	3/8" BSPF	3/8" BSPM	-5/+65°C	12Kg
AW1015	10mm	15m	240	3/8" BSPF	3/8" BSPM	-5/+65°C	12Kg
AW1020	10mm	20m	240	3/8" BSPF	3/8" BSPM	-5/+65°C	12Kg
AW1215	12mm	15m	240	1/2" BSPF	1/2" BSPM	-5/+65°C	12Kg
AW1218	12mm	18m	240	1/2" BSPF	1/2" BSPM	-5/+65°C	12Kg

Heavy Duty Air reel model AWHD1210 fitted with EPDM rubber hose. Ideal for air applications in fabrication areas where welding spatter adversely affects standard hoses.

AWHD1210	12mm	10m	240	1/2" BSPF	1/2" BSPM	-5/+65°C	12Kg
----------	------	-----	-----	-----------	-----------	----------	------

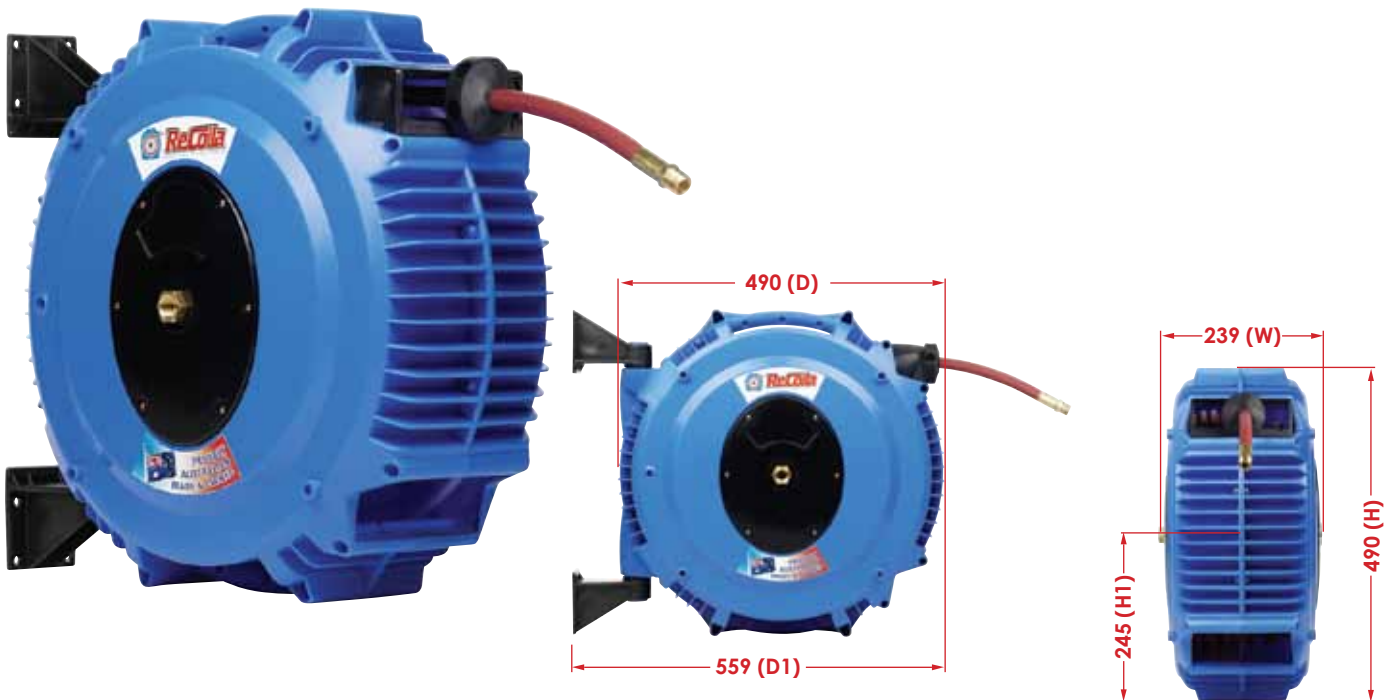

Note:  
NPT, JIC, JIS, Metric threads are available.  
Maximum hose pressure rating is based at 30°C.

# Gen III Features & Benefits

ReCoila® Gen III composite construction reels lead the world in design, functionality, reliability and innovative features.

ReCoila® was one of the first in the world to develop and manufacture composite spring rewind reels and today we continue to be world leaders.

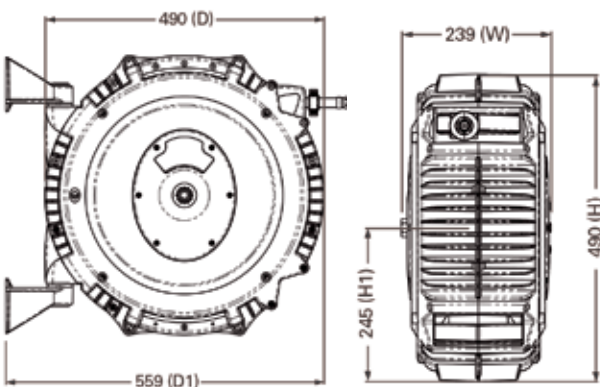

- Up to a 5 year warranty
- Highest quality 'finished edge' spring steel strip
- Full flow swivels and fluid paths
- Positive crimp hose fittings
- All position positive latching system
- Tough, impact, corrosion resistant and UV stabilized polypropylene with anti static and flame retardants
- Unique ratchet tensioning system
- Heavy Duty wall mounting swivel system
- Replaceable protective mouth guard
- Large side covers for easy access in servicing and maintenance routines
- Food grade approved materials
- Unique service locking pin port for added safety
- Two part fully adjustable bumper
- Detailed operation and service manual
- Easy mount drill hole pattern supplied

